

# Lithium-Ion 24V LFP battery module

## - Manual -

MGLFP240280, MGLFP241280, MGLFP242280 (LFP 280Ah)

MGLFP240304, MGLFP242304 (LFP 304Ah)

MGLFP240230, MGLFP241230, MGLFP242230 (LFP 230Ah)

**MG Energy Systems B.V.**





Copyrights © 2024 MG Energy Systems B.V.  
All Rights Reserved

This publication or parts thereof, may not be reproduced in any form, by any method, for any purpose.

For conditions of use and permission to use this manual for publication in other than the English language, contact MG Energy Systems B.V..

MG ENERGY SYSTEMS B.V. MAKES NO WARRANTY, EITHER EXPRESSED OR IMPLIED, INCLUDING BUT NOT LIMITED TO ANY IMPLIED WARRANTIES OF MERCHANTABILITY OR FITNESS FOR A PARTICULAR PURPOSE, REGARDING THESE MG ENERGY SYSTEMS B.V. PRODUCTS AND MAKES SUCH MG ENERGY SYSTEMS B.V. PRODUCTS AVAILABLE SOLELY ON AN “AS IS” BASIS.

IN NO EVENT SHALL MG ENERGY SYSTEMS B.V. BE LIABLE TO ANYONE FOR SPECIAL, COLLATERAL, INCIDENTAL, OR CONSEQUENTIAL DAMAGES IN CONNECTION WITH OR ARISING OUT OF PURCHASE OR USE OF THESE MG ENERGY SYSTEMS B.V. PRODUCTS. THE SOLE AND EXCLUSIVE LIABILITY TO MG ENERGY SYSTEMS B.V., REGARDLESS OF THE FORM OF ACTION, SHALL NOT EXCEED THE PURCHASE PRICE OF THE MG ENERGY SYSTEMS B.V. PRODUCTS DESCRIBED HERE IN.

MG Energy Systems B.V. reserves the right to revise and improve its products as it sees fit. This publication describes the state of this product at the time of its publication and may not reflect the product at all times in the future.

## TABLE OF CONTENTS

1	GENERAL .....	1
1.1	Document history .....	1
1.2	Terms, abbreviations, and definition .....	2
2	SAFETY INSTRUCTIONS.....	3
2.1	Safety message level definition .....	3
2.2	User health and safety .....	3
2.2.1	General precautions .....	3
2.2.2	Qualifications and training.....	4
2.2.3	Non-compliance risks .....	4
2.2.4	Risk assessment.....	4
2.2.5	Unacceptable modes of operation .....	4
3	TRANSPORT, STORAGE, UNPACKING AND HANDLING .....	5
3.1	Transport .....	5
3.2	Storage .....	5
3.3	Unpacking and handling.....	6
3.3.1	Lifting the battery module .....	6
3.3.2	Scope of delivery .....	7
4	GENERAL DESCRIPTION.....	8
4.1	Battery system components.....	8
4.2	Functional description.....	8
4.3	Example systems.....	9
4.3.1	Low voltage systems.....	9
4.3.2	High voltage systems.....	11
5	MODELS.....	12
5.1	Models and configurations.....	12
5.1.1	Battery designation .....	13
5.2	Identification label .....	14
5.2.1	Other labels.....	14
5.3	Approvals and standards.....	15
6	OVERVIEW.....	16
6.1	Connection overview .....	16
6.2	Connections details.....	17

6.2.1	RJ45 CAN-bus connector details .....	17
6.2.2	M12 CAN-bus connector details .....	18
6.2.3	Power connections .....	19
6.3	Status indication .....	21
6.3.1	Indication .....	21
7	INTEGRATION REQUIREMENTS AND INSTRUCTIONS .....	22
7.1	Risk assessment .....	22
7.2	Location .....	22
7.2.1	Environment.....	22
7.2.2	Thermal management .....	22
7.3	Placement.....	24
7.3.1	Placement in battery box.....	24
7.3.2	Positioning the battery .....	24
7.3.3	Mounting considerations.....	25
7.3.4	Battery module spacing requirements .....	25
7.4	Electrical .....	26
7.4.1	Power cables .....	26
7.4.2	Parallel configuration .....	26
7.4.3	Paralleling using the Distributor LV .....	30
7.4.4	Paralleling using a custom bus bar connection system .....	30
7.4.5	Series configuration.....	31
7.4.6	Charging.....	33
8	INSTALLATION .....	34
8.1	Tooling.....	34
8.2	Installation procedures .....	35
8.3	Mounting procedure .....	35
8.4	Electrical connection procedure .....	35
8.4.1	Equipotential bonding connection procedure .....	36
8.4.2	Positive and negative power connection procedure.....	37
8.4.3	CAN-bus connection procedure .....	42
8.5	Installing the top ingress protection cover.....	45
8.5.1	Placing the cover .....	46
8.5.2	Removing the cover.....	48

8.5.3	Cutting the cover .....	48
8.6	Fuse replacing procedure .....	50
8.6.1	Non-fused battery pole.....	50
8.6.2	Replacement instructions .....	50
9	COMMISSIONING.....	52
10	DECOMMISSIONING PROCEDURES.....	53
10.1	Procedure: removing a malfunctioning battery module.....	53
10.1.1	Detecting malfunctioning .....	53
10.1.2	Monitoring the battery module .....	54
10.1.3	Remove and secure the battery module .....	54
10.2	Procedure: removing a battery module from a functioning system.....	55
10.2.1	Removing battery modules.....	55
10.2.2	Prepare the battery module for a longer storage period .....	55
11	SERVICE .....	56
11.1	Maintenance.....	56
11.1.1	Cleaning .....	56
11.2	End-of-life .....	56
11.3	Disposal .....	56
12	BOUNDARY LIMITS.....	57
12.1	Limits .....	57
12.1.1	Cell voltage.....	57
12.1.2	Cell temperature charging .....	58
12.1.3	Cell temperature discharging.....	58
12.1.4	Power terminal temperature .....	58
12.1.5	Current.....	59
12.1.6	Balancing.....	59
13	TECHNICAL SPECIFICATIONS.....	60
14	DIMENSIONS.....	60
15	CONTACT DETAILS.....	61
15.1	Sales .....	61
15.2	Technical support.....	61

## 1 GENERAL

Before continuing read the instructions in this chapter carefully and be sure the instructions are fully understood. If there are questions after reading the instructions please consult MG Energy Systems.

### 1.1 Document history

Table 1 - Document history

Rev.	Date	Changes	Revision author
0.1	18-08-2020	Initial document	A-T. Rienstra
1.0	20-09-2020	Added schematics, detailed connector information etc.	M. Scholten
1.1	20-10-2020	Minor changes and typo fixes.	M. Scholten
1.2	11-11-2020	Fixed typos.	M. Scholten
1.3	31-05-2022	Adjusted discharged voltage limits.	W. Portinga
1.4	7-11-2022	<ul style="list-style-type: none"> <li>- Updated images</li> <li>- Extended storage notes text in chapter 3.2.</li> <li>- Changed voltage levels and number of battery modules in series to 144V and 6 modules in series.</li> <li>- Added chapter risk assessment to chapter 2.2.4.</li> <li>- Added "Other labels" to chapter 5.2.1.</li> <li>- Updated dummy fuse article number in chapter 6.2.3.1.</li> <li>- Removed 2C heat rejection from chapter 7.2.2.1.</li> <li>- Added chapter 7.3.1 Placement in battery box.</li> <li>- Changed float voltage in chapter 7.4.6.2.</li> <li>- Added chapter 8.1 Tooling.</li> <li>- Updated connection of positive and negative power cables and CAN-Bus connections.</li> <li>- Extended the commissioning in chapter 9.</li> <li>- Extended the maintenance in chapter 0.</li> <li>- Changed "Dummy fuse" to non-fused battery pole in the complete document.</li> </ul>	M. Scholten
1.5	12-06-2023	<ul style="list-style-type: none"> <li>- Removed additional boundary limit.</li> <li>- Added the 304 Ah battery type</li> </ul>	M. Scholten
1.6	17-08-2023	<ul style="list-style-type: none"> <li>- Added the battery box link</li> <li>- Minor changes and typo fixes</li> </ul>	W. Jansma
1.7	29-01-2024	<ul style="list-style-type: none"> <li>- Added the LFP230 M12, HV battery type</li> <li>- Changed risk assessment text in chapter 2.2.4 and 7.1.</li> <li>- Added regular charging in chapter 7.4.6.1.</li> <li>- Added decommissioning procedures in chapter 10.</li> </ul>	M. Scholten

## 1.2 Terms, abbreviations, and definition





Table 2 - Terms, abbreviations, and definitions

Battery cell	<i>Battery cell</i> ; the smallest building block in a battery, a chemical unit. Cell is the bare Lithium-Ion battery cell.
Battery module	<i>Battery module</i> ; is an assembly of submodules, BMS and outer enclosure.
Battery stack	<i>Battery stack</i> ; is a set of multiple cells in cell cassettes constructed as one.
BMS	<i>Battery Management System</i> ; The BMS is the electronics that monitors the battery cell parameters to keep it within the operation specifications.
CAN-bus	<i>Controller Area Network bus</i> ; CAN-bus is a standard serial data-bus that provides data communication between two or more devices.
C-rate	<i>C-Rate</i> ; the current (A) used to charge/discharge the battery system divided by the rated ampere-hours (Ah).
EMS	<i>Energy Management System</i> ; The EMS controls all power sources and consumers in a system.
HVIL	<i>High Voltage Interlock Loop</i> ; is a wire loop which is created for protection of pulling cables from the battery system while in operation. It shuts down the system when loop is not closed.
IC	<i>Integrated Circuit</i> ; is a chip containing an electronics circuit;
MSDS	<i>Material Safety Data Sheet</i> ; is a document that lists information relating to occupational safety and health for the use of various substances and products.
NMEA 2000	<i>National Marine Electronics Association’s NMEA 2000</i> is a plug-and-play communications standard used for connecting marine sensors and display units within ships and boats, standardised in the IEC 61162-1.
PCB	<i>Printed Circuit Board</i> ; is a board containing an electronic circuit;
PCBA	<i>Printed Circuit Board Assembly</i> ; is a board containing an electronic circuit including passive and active components;
SoC	<i>State-of-Charge</i> ; is the remaining capacity in a battery cell or module in percent (%).
SoH	<i>State-of-Health</i> ; is a figure of merit of the condition of a battery (or a cell, or a battery pack), compared to its ideal conditions.

## 2 SAFETY INSTRUCTIONS

### 2.1 Safety message level definition



Table 3 - Safety message levels overview

	<p><b>WARNING:</b> A hazardous situation which, if not avoided, could result in death or serious injury.</p>
	<p><b>CAUTION:</b> A hazardous situation which, if not avoided, could result in minor or moderate injury.</p>
	<p><b>LIMITATION:</b> A limitation to use which must be considered for safe use of the equipment.</p>
	<p><b>ELECTRICAL HAZARD:</b> The possibility of electrical risks if instructions are not followed in a proper manner.</p>
	<p><b>NOTICE:</b></p> <ul style="list-style-type: none"> <li>▪ A potential situation which, if not avoided, could result in an undesirable result or state.</li> <li>▪ A practice not related to personal injury.</li> </ul>

### 2.2 User health and safety

#### 2.2.1 General precautions

This product is designed and tested in accordance with international standards. The equipment should be used according the intended use only.

	<p><b>WARNING:</b> A battery is a permanent energy source which cannot be turned off.</p>
	<p><b>ELECTRICAL HAZARD:</b></p> <ul style="list-style-type: none"> <li>▪ Wear applicable personal protective equipment when working on a battery system.</li> <li>▪ Use insulated tools when working on a battery system.</li> <li>▪ Make sure the locale health and safety regulations for working on battery systems are followed.</li> <li>▪ There is a risk of electrocution and burns when working on higher voltage systems without proper protective gear and special training.</li> </ul>



### 2.2.2 Qualifications and training

The personnel responsible for the assembly, operation, inspection, and maintenance of the battery system must be appropriately qualified. The user company must do the following tasks:

- Define the responsibilities and competency of all personnel working on the battery system.
- Provide instruction and training.
- Ensure that the contents of the operating and safety instructions have been fully understood by the personnel.
- Check the local safety rules and guidelines they have higher preference over the manufacturers specification in case of regulatory conflicts.
- Working on higher voltages requires specific training and certification.

Instructions and training can be carried out by MG Energy Systems B.V. by order of the user company.

### 2.2.3 Non-compliance risks

Failure to comply with all safety precautions can result in the following conditions:

- Death or serious injury due to electrical, mechanical, and chemical influences.
- Environmental damage due to the leakage of dangerous materials.
- Product damage.
- Property damage.
- Loss of all claims for damages.

### 2.2.4 Risk assessment

For every integration of the battery system it might be applicable, depending on the application, to perform a risk assessment.

Goal of the risk assessment is to identify the hazards and determine the corresponding risks for the particular application.

The following topics need to be addressed:

- Fire hazards (fire from the batteries, fire from external source etc.)
- Environmental hazards (moisture, water ingress, vibration, heat etc.)
- Electrical hazards (short-circuit, cable dimensioning, cable routing etc.)
- Installation and operational hazards (lifting, communication, power loss etc.)

### 2.2.5 Unacceptable modes of operation

The operational reliability of this product is only guaranteed when it is used as intended. The operating limits on the identification tag and in the data sheet may not be exceeded under any circumstances. If the identification tag is missing or worn, contact MG Energy Systems B.V. for specific instructions.



---

**WARNING:**

The battery modules may only be used in combination with a master BMS.  
[\(MG Master LV](#) or [MG Master HV](#))

---

### 3 TRANSPORT, STORAGE, UNPACKING AND HANDLING

#### 3.1 Transport

The package and transport instructions provided by the manufacturer must be followed under all circumstances.

Notes on transport:

- Use original packaging materials.
- Lithium-Ion batteries are dangerous goods and must be transported according to the applicable rules.
- Transportation company and shipper must be qualified to transport and package dangerous goods.
- The SoC during transport must be  $\leq 30\%$ .



For details on transport of this battery module see the [MSDS](#) and [general transport instructions](#).



**CAUTION:**

It is not allowed to transport, connect or operate a damaged battery.



**NOTICE:**

No liability can be accepted for damage during transport if the equipment is not transported in its original packaging or if the original packaging is opened before the destination is reached.



**NOTICE:**

The SoC of the battery as delivered from factory is  $\leq 30\%$ .

#### 3.2 Storage

The storage instructions provided by the manufacturer must be followed in all circumstances.

Notes on storage:

- Battery module must be stored in its original packaging.
- Store in a dry, clean, and conditioned location.
- Local regulations for storage of dangerous goods/Lithium-Ion batteries may be applicable.
- Recommended storage temperature of the battery module is between  $+10^{\circ}\text{C}$  to  $+25^{\circ}\text{C}$ .
- It is recommended to limit the battery charge between 50% and 70% SoC. This will limit calendric aging.

The battery module’s SoC is decreasing 1% per year when not connected to any equipment, including MG Master LV or MG Master HV. Recharging is required when the voltage is in the range of the cut-off voltage.



**NOTICE:**

Check the MG Master LV or MG Master HV manual for storage of a connected system.



**NOTICE:**

Check the voltage of the stored battery module every year. When the battery module voltage is < 24 VDC, recharging is required. Contact MG Energy Systems for specific instructions and tools.



**NOTICE:**

Local regulations for storage of dangerous goods/Lithium-Ion batteries may be applicable.

### 3.3 Unpacking and handling

Follow these handling guidelines when handling the product to prevent damage during unpacking:

- Use care when handling the product.
- Leave protective caps and covers on the product until installation.

#### 3.3.1 Lifting the battery module

Use the handles on the side of the battery module for lifting:

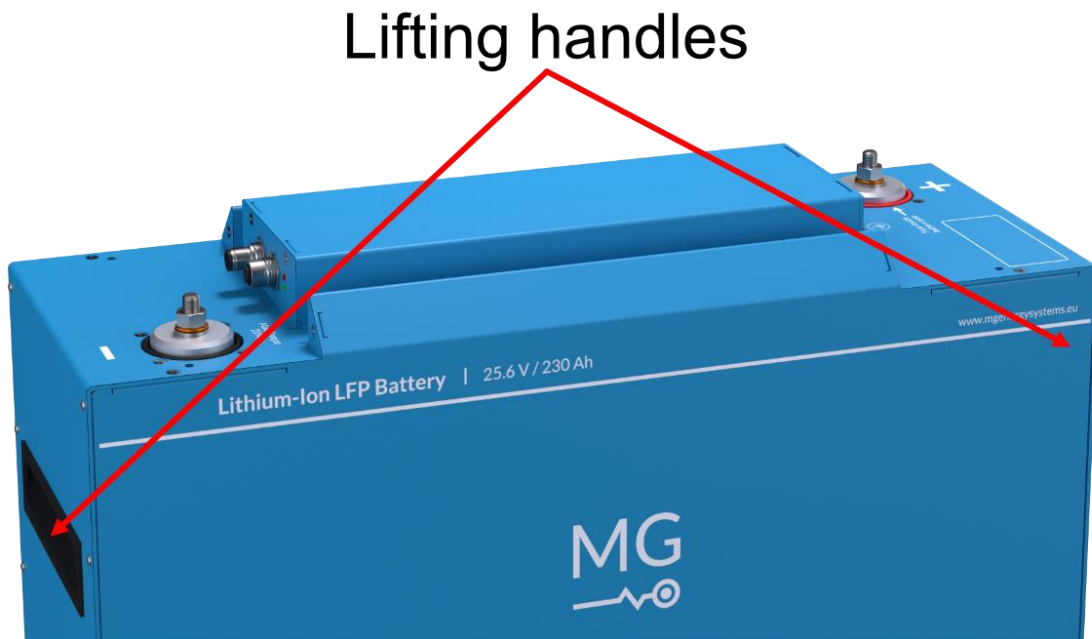

Figure 1 - LFP Lifting handles



**CAUTION:**

Always take the local applicable standards and regulations regarding the prevention of accidents into account when handling the product.



---

**CAUTION:**

Be aware of the total mass of the product and do not lift heavy objects unassisted.

---

### 3.3.2 Scope of delivery

The scope of delivery is as following:

- [MG LFP 24V battery module](#) of type as described in chapter 5.
- Quick installation guide: [LFP 24V](#)
- Top ingress protection cover LFP 24V Series article numbers:  
LFP 280 / LFP 304 = MG4000444,  
LFP 230 = MG4000502
- Non-fused battery pole (article number: MG4000034).  
Only supplied with M12 batteries:  
MGLFP241230  
MGLFP242230  
MGLFP241280  
MGLFP242280  
MGLFP241304  
MGLFP242304



---

**NOTICE:**

Not within the scope of delivery:

- Power cables and connectors (details can be found in chapter 6.2.3).
  - Communication cables and connectors (details can be found in chapter 6.2).
-

## 4 GENERAL DESCRIPTION

The LFP battery series is based on LiFePO<sub>4</sub> chemistry. The next generation battery cells of this chemistry gives this battery module a high energy density and long cycle life. A modular and compact design makes system integration more flexible, especially in refit applications. The passive cooling concept keeps integration simple and straight forward.

These features make this battery suitable for large energy storage applications as well as small peak power packs in hybrid solutions.

### 4.1 Battery system components

MG Energy Systems Lithium-Ion battery system consists of the following components:

- One or more [MG LFP battery modules](#) of the same type;
- One [MG Master LV](#) or [MG Master HV](#) battery management system; Details of these battery management controllers can be found in their separate description documents;
- [MG Energy Monitor](#) (optional);
- [MG SmartLink MX](#) for parallel redundant control (optional);

### 4.2 Functional description

MG's system philosophy is to have one master BMS, e.g. a MG Master LV or MG Master HV, per bank of battery modules which communicates with one or more slave BMSs integrated in the Lithium-Ion battery module(s). The slave BMSs are monitoring the battery cell parameters like cell voltage and cell temperature. Besides monitoring, the slave BMS also controls balancing of cells based on the input of the master BMS.

All these parameters are send to the MG Master LV or MG Master HV via a dedicated CAN-bus which collects all the data and monitors these parameters with different thresholds. When a parameter exceeds the threshold this will first be communicated to the user via the, separated, auxiliary CAN-bus or the I/O connections. If the exceeded threshold stays, the master BMS has the possibility to disconnect the batteries from the system by opening the main contactors.

Functional and safety features of the MG LFP battery module are:

- Robust chemistry;
- Modular design;
- High energy density;
- Plug and Play installation: Automatic configuration;
- Low voltage solutions: 24 V up to 96 V;
- High voltage solutions: Up to 144 V (6 modules in series);
- RJ45 or M12 CAN-Bus connector options;

### 4.3 Example systems

Different kind of battery system configurations can be created because of the modular design. Battery modules can be placed in series and parallel to create higher voltages and larger capacities.

#### 4.3.1 Low voltage systems

Low voltage systems up to 96 VDC are setup with the MG Master LV series. For more information about the MG Master LV, please refer to the data sheet and manual. The example in Figure 2 and Figure 3 are simplified schematics which are not showing all the details.

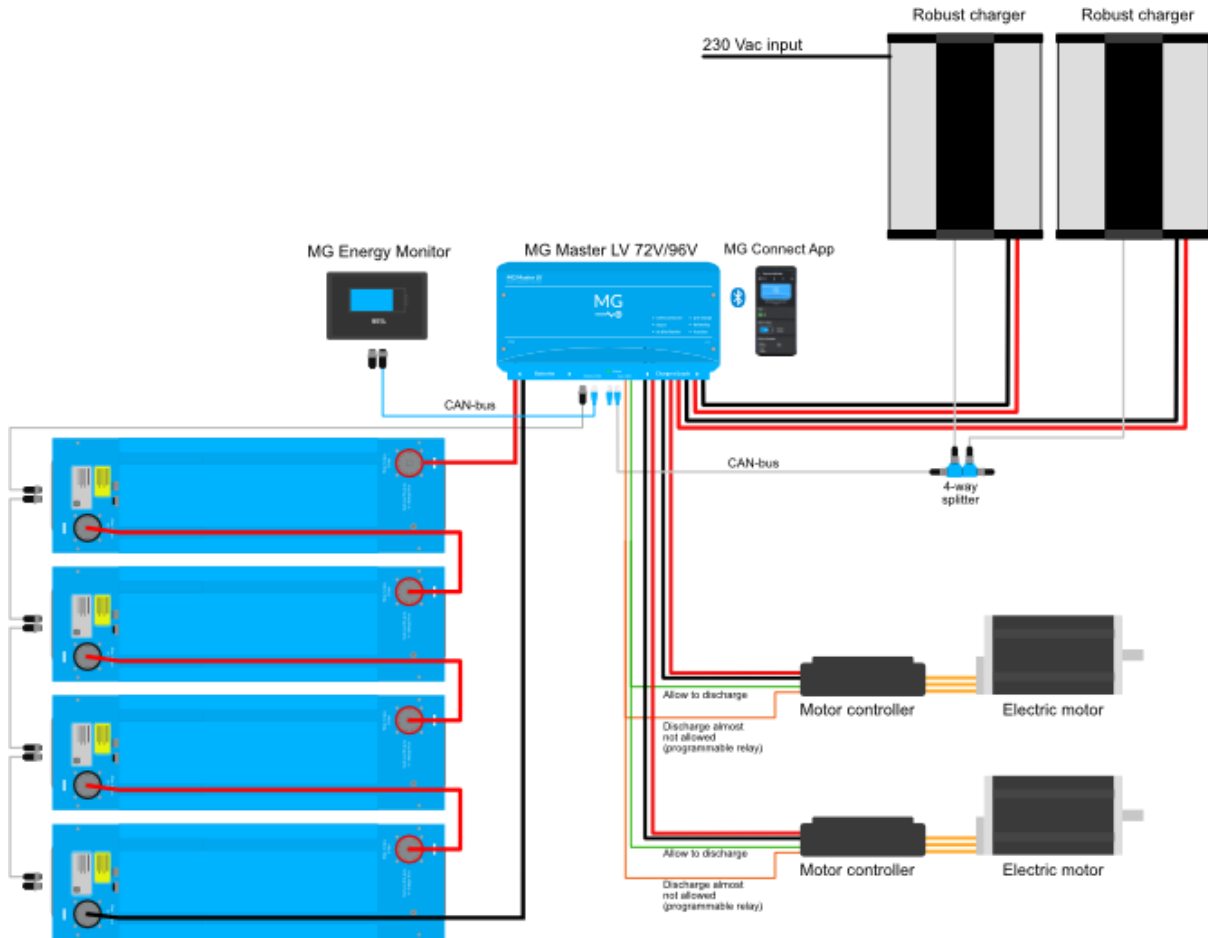

Figure 2 - 96 VDC propulsion system for industrial and marine applications

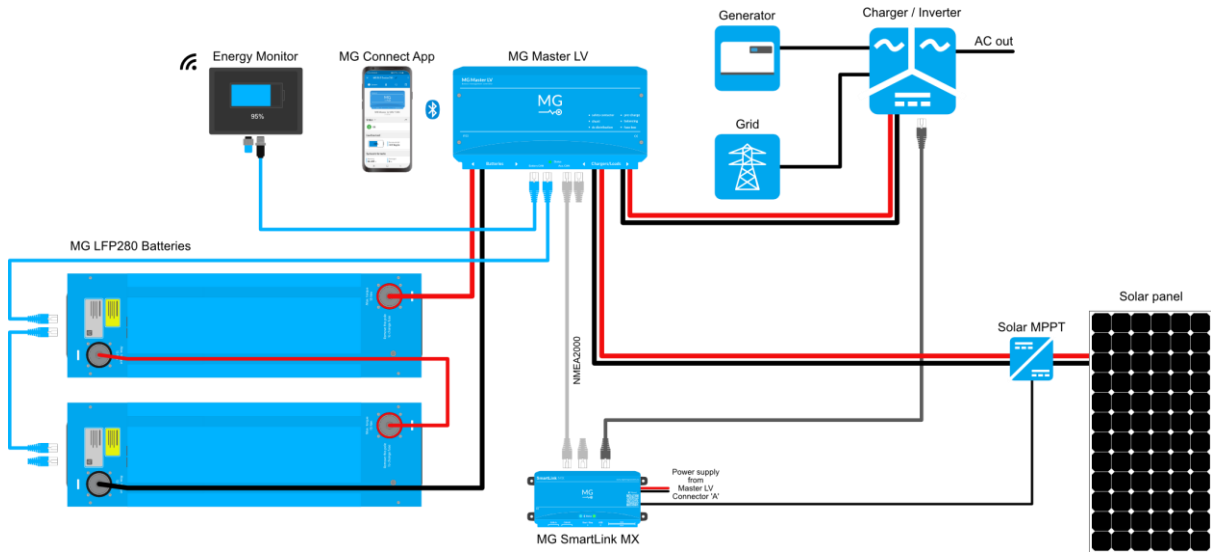

Figure 3 - 48 V small ESS/Solar/Off-grid system

### 4.3.2 High voltage systems

High voltage systems up to 144 VDC are setup with the MG Master HV series. For more information about the MG Master HV, please refer to the data sheet and manual. The example in Figure 4 is a simplified schematic which is not showing all the details.

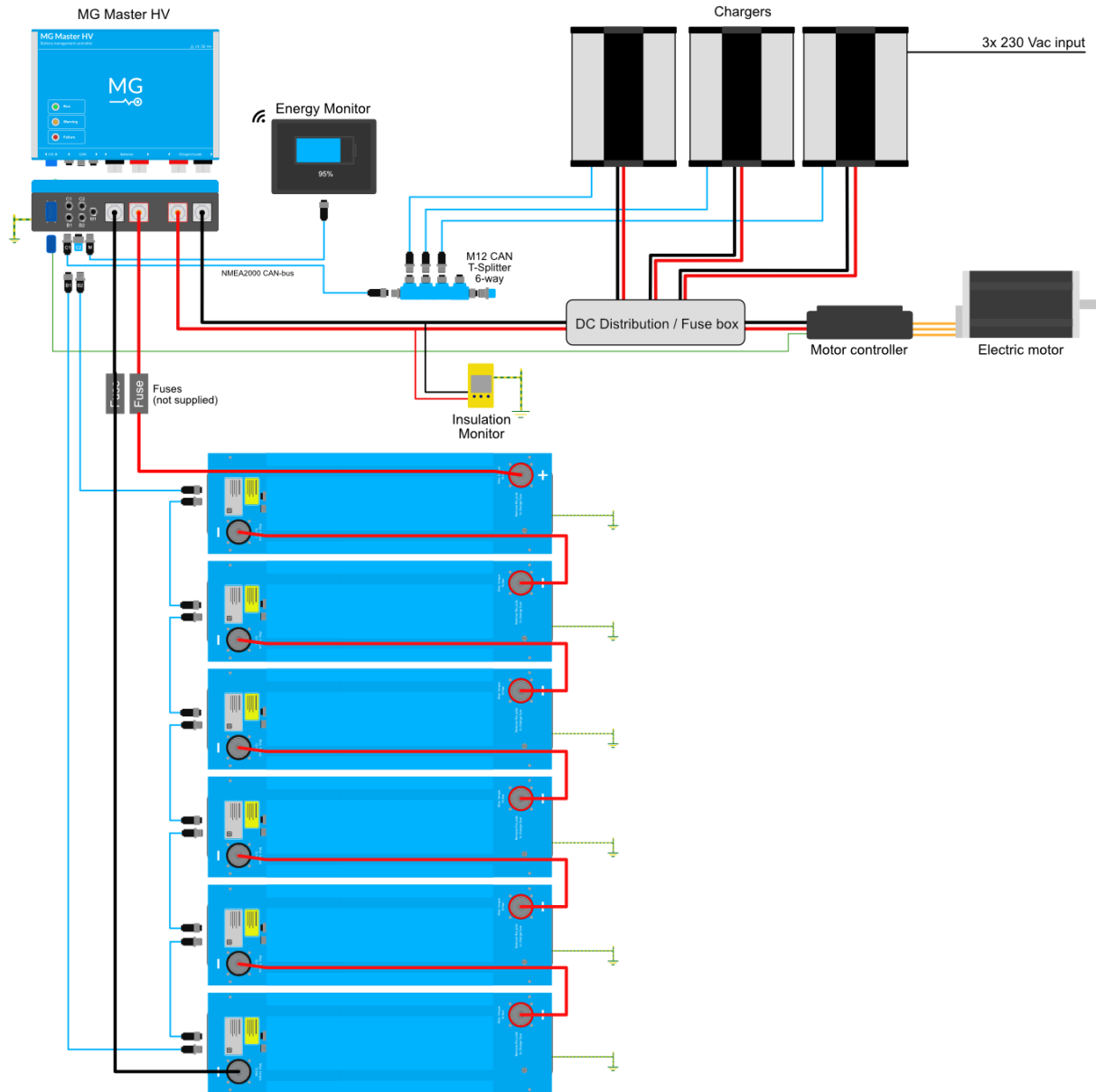

Figure 4 - 144 VDC propulsion system for industrial or marine applications



## 5 MODELS

The LFP Series has different models and configurations available. The main differences are battery module capacity, maximum system voltage and CAN-Bus connector types.

### 5.1 Models and configurations

Table 4 lists the available battery module configurations.

Table 4 - Battery module configurations

Article number	Description	Remarks
MGLFP240280	MG LFP Battery 25.6V/280Ah/7200Wh	24 V up to 96 V, RJ45 connectors
MGLFP241280	MG LFP Battery 25.6V/280Ah/7200Wh (M12)	24 V up to 144 V, M12 connectors
MGLFP242280	MG LFP Battery 25.6V/280Ah/7200Wh (M12, HV)	24 V up to 470 V, M12 connectors
MGLFP240230	MG LFP Battery 25.6V/230Ah/5800Wh	24 V up to 96 V, RJ45 connectors
MGLFP241230	MG LFP Battery 25.6V/230Ah/5800Wh (M12)	24 V up to 144 V, M12 connectors
MGLFP242230	MG LFP Battery 25.6V/230Ah/5800Wh (M12, HV)	24 V up to 470 V, M12 connectors
MGLFP240304	MG LFP Battery 25.6V/304Ah/7800Wh	24 V up to 96 V, RJ45 connectors
MGLFP242304	MG LFP Battery 25.6V/304Ah/7800Wh (M12, HV)	24 V up to 470 V, M12 connectors

---

#### NOTICE: Using different LFP battery models in one system

##### Using the LFP280 and LFP304 in the same system is possible.

Many systems are using the MG LFP280 battery module. The firmware in both the MG Master LV and HV is accepting these different modules in one battery bank. This is implemented to add backwards compatibility for service and support requests, because the MG LFP304 replaces the MG LFP280 since Mid. 2023. The LFP304 is an upgrade of the LFP280 and therefore can be integrated in systems with existing LFP280 batteries.



##### Using the LFP230 in combination with the MG LFP280 or MG LFP304 in one battery bank is NOT possible

In general when designing new battery banks, it is not recommended and supported to use different battery models in one battery bank. For example the MG LFP230 battery module cannot be combined with a MG LFP304.

---

### 5.1.1 Battery designation

As per IEC 62620 it is required to state a standard designation per battery module configuration. For the LFP series lithium-ion battery these are given in table 5.

Table 5 - Battery module designation as per IEC 62620

Article number	Designation
MGLFP240280, MGLFP241280, MGLFP242280	IFpP/72/174/200/[1P8S]E/-10NA/95
MGLFP240230, MGLFP241230, MGLFP242230	IFpP/55/174/205/[1P8S]E/-10NA/95
MGLFP240304, MGLFP242304	IFpP/73/175/205/[1P8S]E/-10NA/95

## 5.2 Identification label

The identification label of the MG LFP battery module is located at the front of the enclosure.

Example identification label:

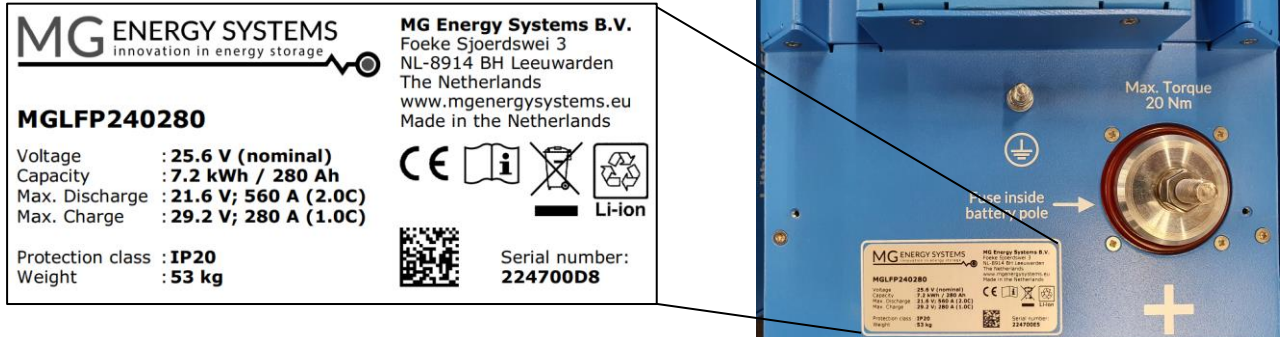

Figure 5 - Example identifications label

The identifications label shown in figure 5 contains written information about the product. The explanation of the symbols used on the identification label is stated in table 6.

Table 6 - Identification lable logo explanation

	Declaration of conformity with health, safety, and environmental protection standards for products sold within the European Economic Area as per directive 2014/35/EU.
	Symbol indication the manual must be read before installation and use of the device.
	Device is treated according the Waste Electrical and Electronic Equipment (WEEE) Directive 2012/19/EU.
	GS1 data matrix type barcode containing detailed product information.

### 5.2.1 Other labels

Figure 6 shows the additional labels on the battery module.

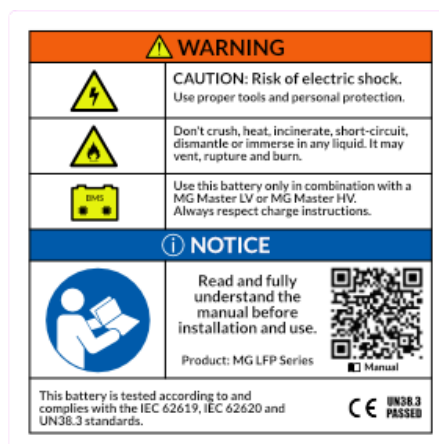

Figure 6 - Additional warning and informational labels

### 5.3 Approvals and standards

The LFP battery conforms to an extensive list of standards and tests.

IEC 62619
EN 62620

- [Declaration of Conformity LFP 280 Ah series](#)
- [Declaration of Conformity LFP 230 and LFP 304 Series](#)
- [Material safety datasheet](#)

A complete list of all performed tests can be found at the following link:

[LFP 24V List of Standards and Tests](#)



---

**NOTICE:**

IEC62619 certification for the LFP 230 and LFP 304 are in progress.

---

## 6 OVERVIEW

This chapter shows an overview of the LFP battery.

Each battery module contains the following common parts:

- Negative battery pole connection;
- Positive battery pole connection;
- BMS CAN-bus connection, either RJ45 or M12;
- Status LEDs;

### 6.1 Connection overview

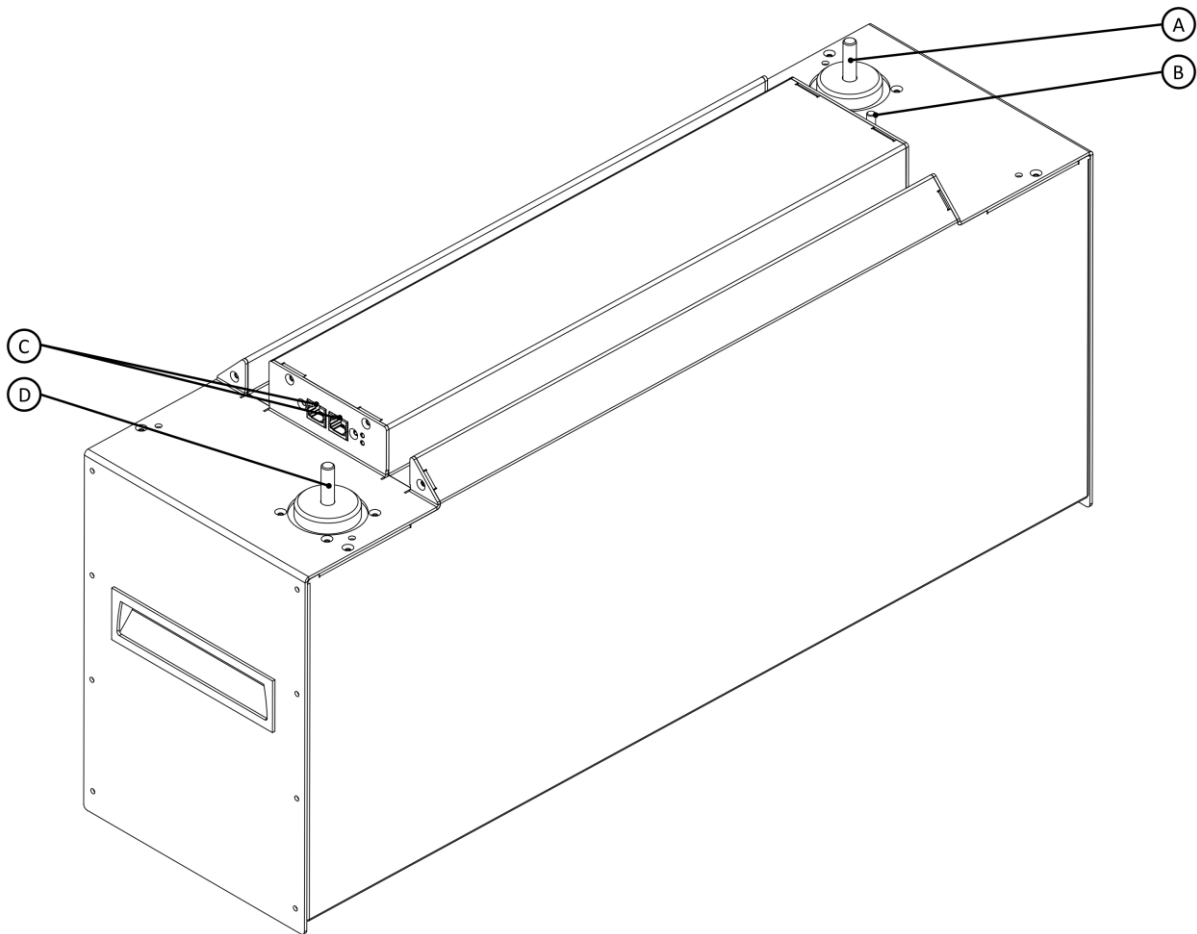

Figure 7 – LFP 280 Ah module overview

Table 7 - Module connection overview

Part	Description
A	Positive power connection (including fuse). M8 bolt connection.
B	Equipotential bonding connection.
C	CAN-Bus communication, either RJ45 or M12.
D	Negative power connection. M8 bolt connection.

## 6.2 Connections details

Each battery module contains two CAN-Bus connectors to connect to the MG Master BMS and to the next battery, if any.

This CAN-Bus connection is used for several functions:

- Data communication between battery module(s) and master BMS;
- The battery module uses the V+ to enable the power of the internal BMS;

The LFP Series have the option to have RJ45 or M12 CAN-Bus connectors.

### 6.2.1 RJ45 CAN-bus connector details

The standard connectors in the LFP Series are the RJ45 CAN-Bus connectors.

#### 6.2.1.1 Connector details

Typical cables that are used for the RJ45 CAN-Bus connections are standard CAT 5 Ethernet network patch cables.

Table 8 – RJ45 connector details

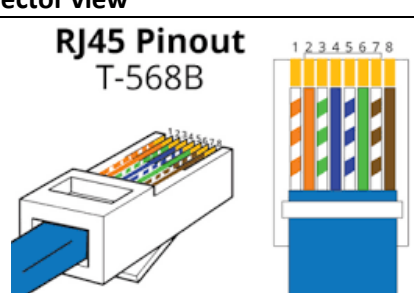
Pin	Description	Connector view
1		 <p style="text-align: center;"><b>RJ45 Pinout T-568B</b></p>
2		
3	GND	
4		
5		
6	V+	
7	CAN-H	
8	CAN-L	



**NOTICE:**

Always use standard prefabricated Ethernet network patch cables (straight).

### 6.2.2 M12 CAN-bus connector details

The LFP Series have the option to contain M12 CAN-Bus connectors.

#### 6.2.2.1 Connector details

The connectors used for connecting the CAN-bus are all of the same type, namely a circular M12 connector with 5 positions and A-coded keying.

Table 9 - Circular M12 connector with 5 positions A-coded details

Pin	Description	Connector view
1	Shield	<p style="text-align: center;">M12, 5-pin, A-coded</p> <p style="text-align: center;">Male                  Female</p>
2	V+	
3	GND	
4	CAN-H	
5	CAN-L	

Cables to be used for the battery system are typically referred to as NMEA 2000 or DeviceNet compatible cables. The minimum requirements for cables are:

- Twisted pair connected to pins 4 and 5 for communication with a minimum wire cross sectional area of 0.2 mm<sup>2</sup> (24 AWG).
- Pair of conductors connected to pin 2 and 3 for power and HVIL with a minimum wire cross sectional area of 0.34 mm<sup>2</sup> (22 AWG).
- Cable with braided shielding connected to pin 1.



**NOTICE:**

Do not use sensor/actor cables. They often don't have any twisted pairs and are therefore not suitable for this application.

### 6.2.3 Power connections

The power connections on the battery module consists of two M8 bolt connections. One is the positive battery pole and one is the negative battery pole.

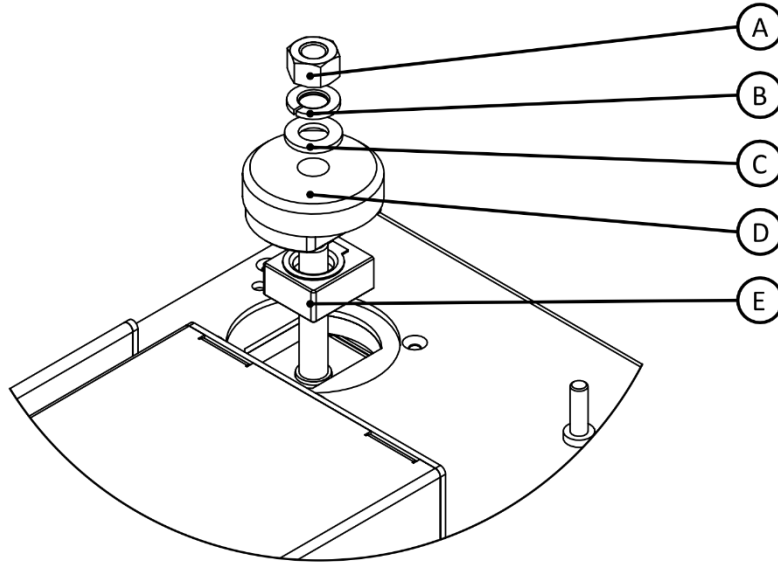

Figure 8 - Battery pole connection overview

Part	Description
A	Nut
B	Spring washer
C	Washer
D	Battery pole
E	Fuse (only positive battery pole)

#### 6.2.3.1 Fuse

The positive battery pole contains a protection fuse. This fuse is a CF8 fuse. See chapter 8.6 for the replacement procedure.

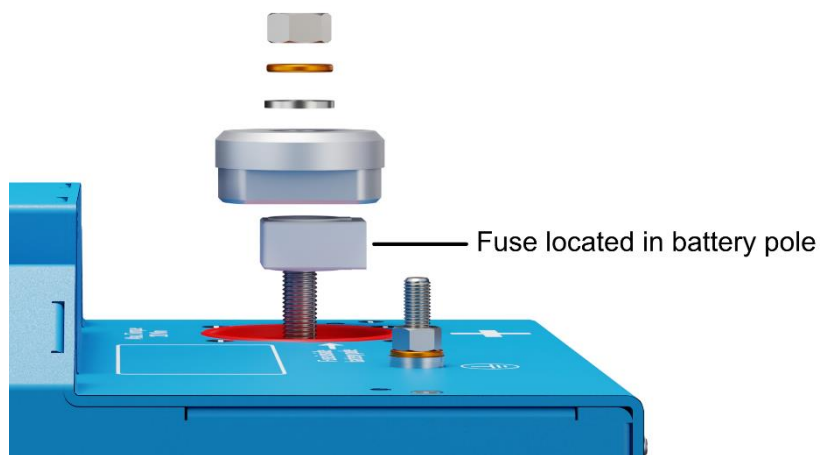

Figure 9 - Fuse location



Fuse types to use:

MG Fuse article number	Fuse current	Fuse manufacturer article number
MGFUSE1580150	150 A	Little fuse CF8 - 155.0892.6151
MGFUSE1580200	200 A	Little fuse CF8 - 155.0892.6201
MGFUSE1580225	225 A	Little fuse CF8 - 155.2892.6221
MGFUSE1580250	250 A	Little fuse CF8 - 155.0892.6251
MGFUSE1580300	300 A	Little fuse CF8 - 155.0892.6301
MG4000034	-	Non-fused battery pole (negative battery pole)

Default fuse types:

Battery type	Default fuse installed
MGLFP240280, MGLFP241280, MGLFP242280	300 A
MGLFP240230, MGLFP241230, MGLFP241230	300 A
MGLFP240304, MGLFP242304	300 A



**NOTICE:**

A broken fuse is indicated by measuring no voltage on the battery terminals. Before measuring the nut must be tightened first.



**WARNING:**

For systems with a voltage above 58 VDC, a non-fused battery pole is mandatory. See chapter 6.2.3.2 and 8.6.1 for more information.



**WARNING:**

In some cases it is required to replace the fuse for a smaller one according to the cable size or can be fused elsewhere in the circuit.

### 6.2.3.2 Non-fused battery pole

Replacing the fuse by a non-fused battery pole is needed in case the battery module is used in series above 58 V. This non-fused battery pole is actually a complete battery pole that replaces the battery pole with fuse holder. See chapter 8.6 for the replacement procedure.

### 6.3 Status indication

Figure 10 shows the location of the status indication LEDs. They are located next to the CAN-bus connections.

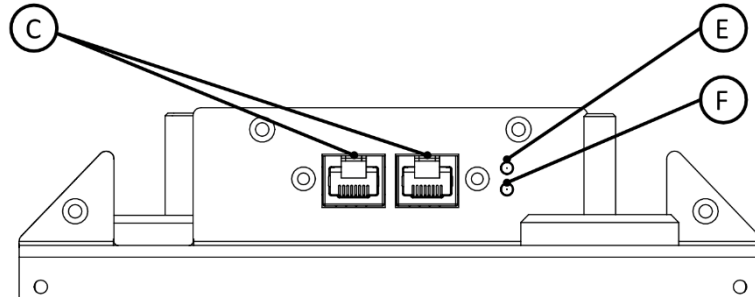

Figure 10 - Status LEDs overview

Part	Description
E	Green LED
F	Red LED

#### 6.3.1 Indication

Table 10 shows the LED states and its meaning.

Table 10 - Status indication

Green LED	Red LED	Description
On	Off	Battery module is powered and internal BMS is operational.
On	On	Identification mode. The Red LED is turned on for a minute by the Diagnostic Tool to identify the battery.
Off	On	Battery module is in bootloader mode. Updating firmware is in progress.
Off	Off	Battery module is Off.

## 7 INTEGRATION REQUIREMENTS AND INSTRUCTIONS

This chapter describes the necessary requirements and instructions for integration of the battery module into the application.

### 7.1 Risk assessment

Performing a risk assessment for the integration of the battery system is depending on the application for which specific rules might apply. For example in a Marine application, class register rules might apply or on other cases standard CE-marking might apply.

MG Energy Systems can supply the necessary basic documentation for risk assessment.



---

**NOTICE:**

Before integration design check the applicable rules for the application where the battery system will be integrated in.

---

### 7.2 Location

The location of the battery system needs special attention, since some regulatory body categorize Lithium-Ion battery systems as hazardous. Check for the local rules for the requirements of the battery system location in the used application.

General recommendations and requirements for the battery space with respect to the battery module are as following:

- Make sure the battery space is in accordance with the applicable rules.
- Ensure the battery space complies with the operating conditions of the batteries.
- Do not place the batteries next to a heat source.
- Take into account the placement requirements in chapter 7.3.

#### 7.2.1 Environment

The battery modules has an IP rating of IP30 and must be placed in a space that is moisture and dust free, non-condensing and protected against fluid (water, oil etc.) ingress from top and bottom.





---

**WARNING:**

Moisture or water can damage the battery and its electronics. This might lead to dangerous situations.

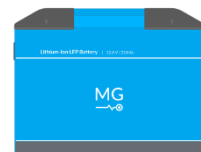
---



#### 7.2.2 Thermal management

The LFP Series battery modules are air cooled. Therefore ambient temperature needs to be taken into account when selecting a space for the installation of the batteries.

- Make sure there is sufficient air flow in the battery space to dispose the heat rejected by the batteries and/or other equipment.
- The most optimized ambient temperature for the batteries is around 25 °C.

**NOTICE:**

Take into account the heat rejection of other equipment in the same space of the batteries.

**NOTICE:**

A significant decrease of cycle life will occur when the battery modules are used at high ambient temperatures.

If forced air ventilation is used for the battery room please make sure the environmental specifications are met. Temperature difference should in no way cause condensation on the battery module nor on other parts of the battery room.

### 7.2.2.1 Heat rejection

Table 11 shows the heat rejection versus charge and discharge rates for every LFP model.

Table 11 – Heat rejection versus charge/discharge rate.

Battery model	LFP 230 Ah
Nominal internal resistance	6 mOhm @ 25 °C
Cooling system	Passive air cooling (convection)
Heat rejection	0.5 C = 80 W 1 C = 318 W

Battery model	LFP 280 Ah
Nominal internal resistance	4.5 mOhm @ 25 °C
Cooling system	Passive air cooling (convection)
Heat rejection	0.5 C = 88 W 1 C = 353 W

Battery model	LFP 304 Ah
Nominal internal resistance	4.5 mOhm @ 25 °C
Cooling system	Passive air cooling (convection)
Heat rejection	0.5 C = 88 W 1 C = 353 W

### 7.3 Placement

This chapter will explain the design requirements for placement of the battery modules.

#### 7.3.1 Placement in battery box

It is recommended to place the battery modules in a steel box or sealed compartment with fire retardant properties. This will protect the battery modules from external environmental abuse such as water or moisture ingress and fire. It also protect the environment from a potential battery fire. The design and the requirement of using a battery box depends on the type of application and the outcome of the risk assessment.

Requirements to the battery box:

- Preferred isolated for 60 minutes fire retardant (A60).
- Fluid and gas tight.
- Gas exhaust connection to outside (safe area).
- Manual or automatic flooding option of this battery box.
- Temperature sensor.
- Smoke sensor.
- No electrical switching equipment or junction boxes inside.
- Place the battery modules with at least 10mm clearance from the floor/bottom.
- Accessibility for commissioning and service of battery modules must be maintained.



**NOTICE:**

Respect the thermal management notes of the battery module in chapter 7.2.2 when used in sealed spaces or compartments.



**NOTICE:**

Always install the ingress cover protection on top of each battery module.

Article numbers:

LFP 280 / LFP 304 = MG4000444,

LFP 230 = MG4000502



**NOTICE:**

Also find the guidelines for placement of batteries in a battery box on the [MG Download Center](#)

---

#### 7.3.2 Positioning the battery

The battery module may be placed upwards only.

Figure 11 shows the possible positions that are allowed.



Figure 11 - Mounting positions of the LFP models

### 7.3.3 Mounting considerations

Mounting of the battery modules can be either done by straps or brackets.



**NOTICE:**

Mounting brackets or straps are not within the scope of delivery.

### 7.3.4 Battery module spacing requirements

Figure 12 shows the minimum spacing of the battery modules. It is mandatory to maintain a clearance of 10 mm from all sides of the battery module.



Figure 12 - Battery spacing requirements

## 7.4 Electrical

This chapter describes the installation and connections of the electrical wiring.

### 7.4.1 Power cables

Cable lengths need to be taken into account when designing a battery system. Batteries can be placed in parallel, for example in 24 VDC systems, or in series up to 144 VDC.



**NOTICE:**

- Use the correct cable type for the applicable system voltage.
  - Use the correct fuses for the applicable cable cross-section and voltage.
  - We recommend to size the cables to limit voltage drop to 1% or less.
- 



**NOTICE:**

Cable lug and battery must be cleaned before connection to ensure a low resistance connections. Check these power connections for excessive temperatures during a load test.

---

### 7.4.2 Parallel configuration

The battery module can set in parallel to create a larger system capacity. The MG Master BMS can handle up to 96 LFP battery modules. Meaning that a 24 VDC system can have 96 LFP battery modules in parallel. For a 48 VDC system is would be 48 LFP battery modules.



**CAUTION:**

Make sure the voltage of each battery module is equal when connecting them in parallel. Excessive high uncontrolled currents can flow between battery modules when the voltage is not equal. This can damage the batteries and might lead to other damage or injury.

---



**NOTICE:**

The power cables of each battery module need to have matching lengths as good as possible when connecting battery modules in parallel.

---

Battery modules can be connected separately in parallel to a Master LV. It has four power connection positions where four batteries could be connected. Refer to the Master LV manual for more information.

Figure 13 shows the most basic parallel connection that is possible. The power connection of each battery is directly connected to a Master LV.

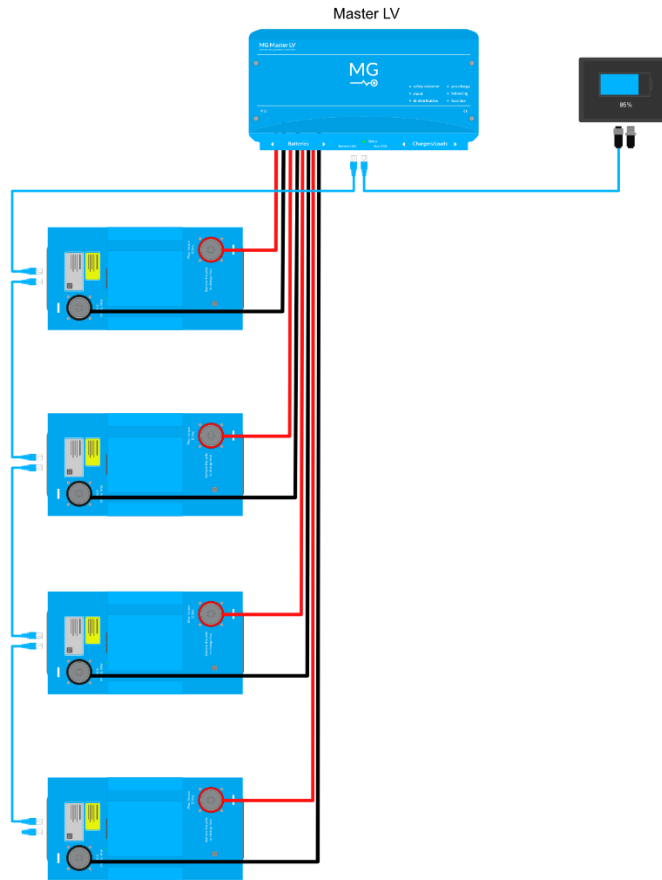

Figure 13 - Four battery module connected in parallel on a single Master LV. Cables must have matching lengths.

There are multiple options when connecting more than four batteries in parallel.

1. Paralleling at the battery modules.
2. Paralleling using the Distributor LV.
3. Paralleling using a custom bus bar connection system.



### 7.4.2.1 Paralleling at the battery modules

Paralleling at the battery modules makes it possible to connect more than four battery modules to a Master LV or other DC distribution. Important is that the cable lengths of the battery modules must be as equal as possible to prevent too much differences during charging and discharging.

Figure 14 shows the connection of two paralleled groups of two battery modules. The two batteries in a group are connected crosswise. This is done to make sure the two batteries have the same total length of power cables and thus the same cable resistance.

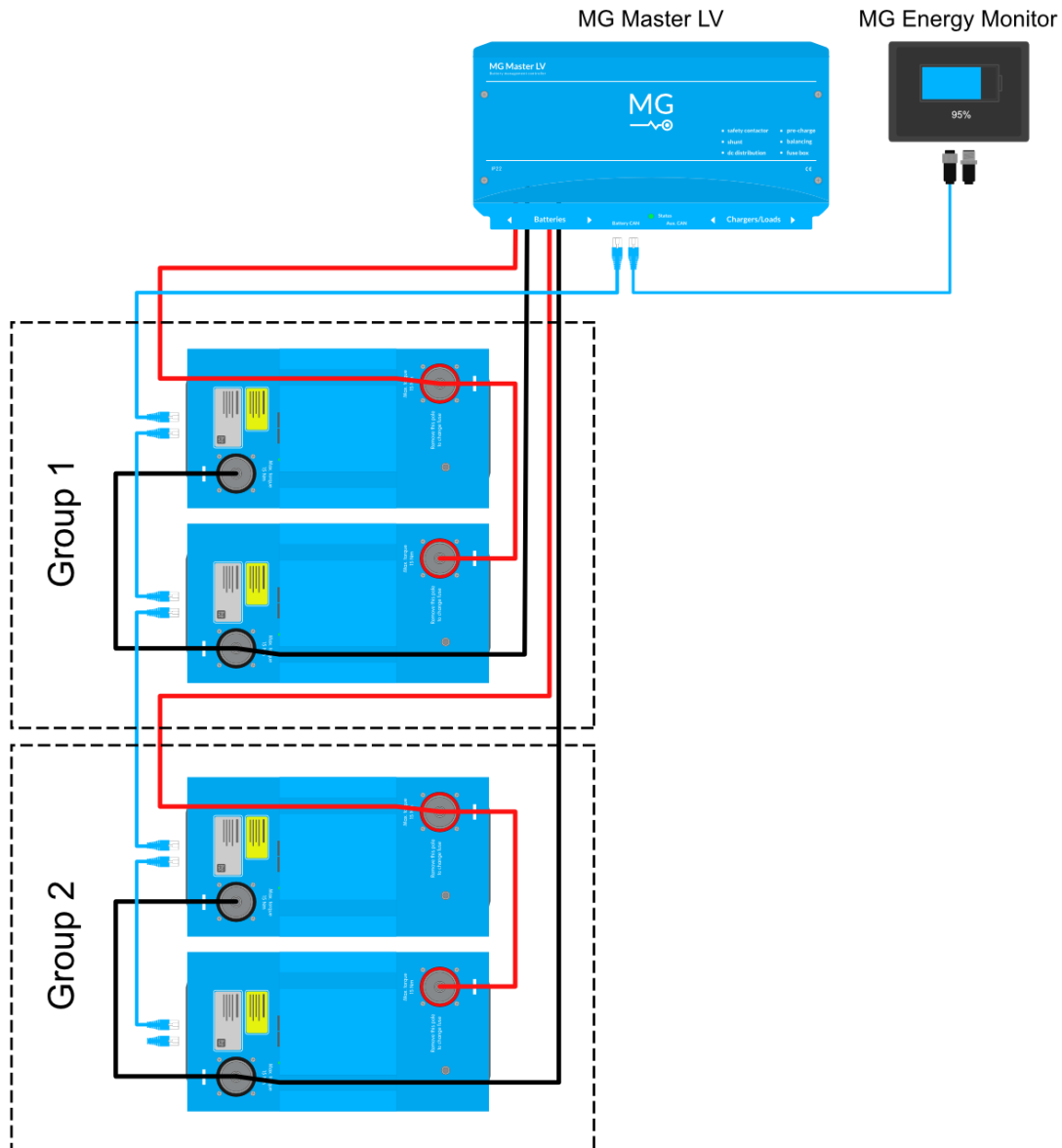

Figure 14 - Example of battery modules paralleled in groups



#### NOTICE:

- Do not create groups larger than five batteries;
- Only use this method in 24 V or 48 V systems;

Figure 15 shows the same paralleling method, but used for a 48 V system where battery modules are connected in series.

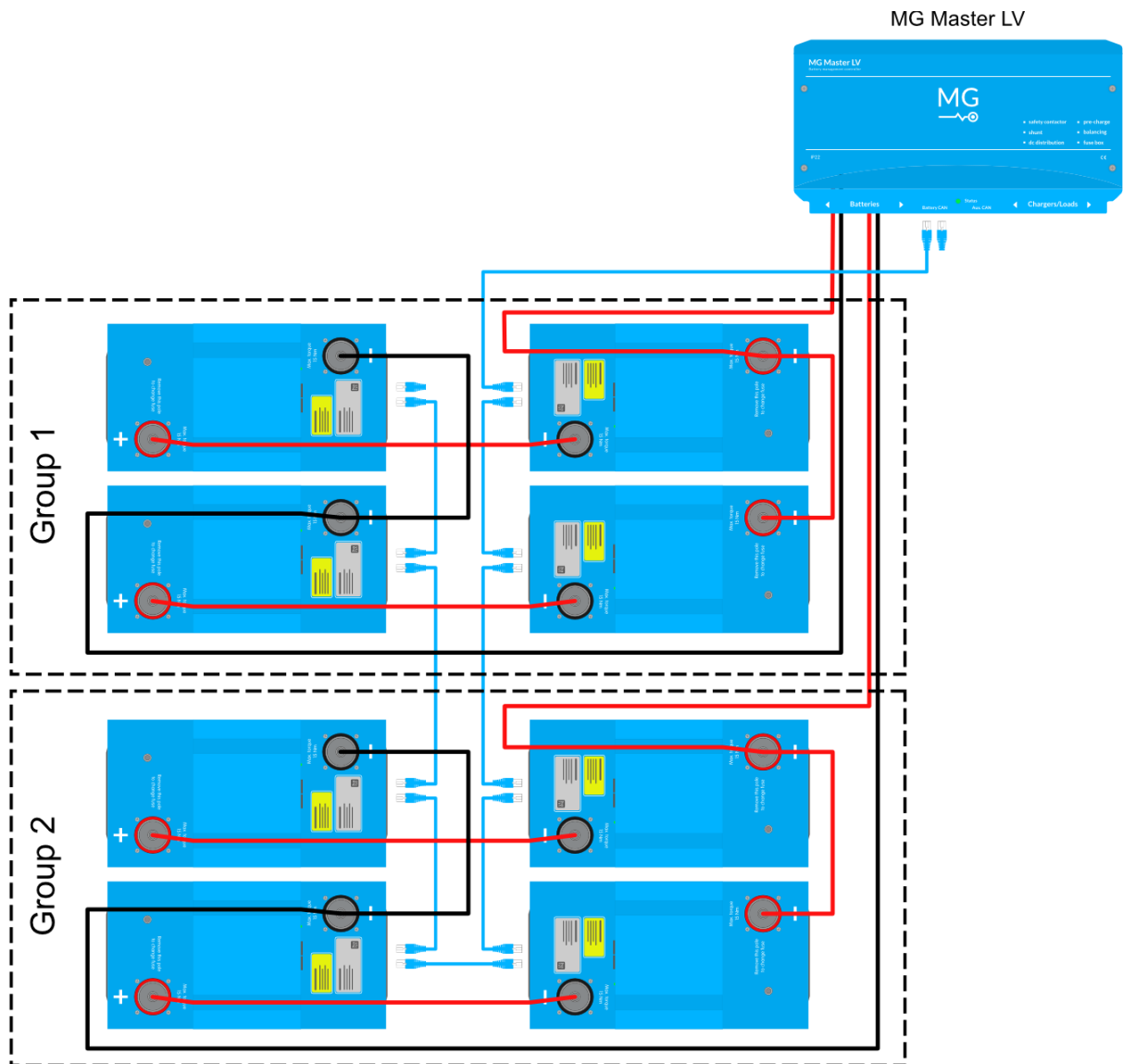

Figure 15 - Example of 48 V system with paralleled groups

### 7.4.3 Paralleling using the Distributor LV

Another option to parallel battery modules is to use the MG Distributor LV (MGLVDIST01001). Basically this DC distribution box has a positive and negative bus bar with the possibility to place fuses. Refer to the manual of the MG Distributor LV for more details.

Figure 16 shows an example of paralleling battery modules using the MG Distributor LV's.

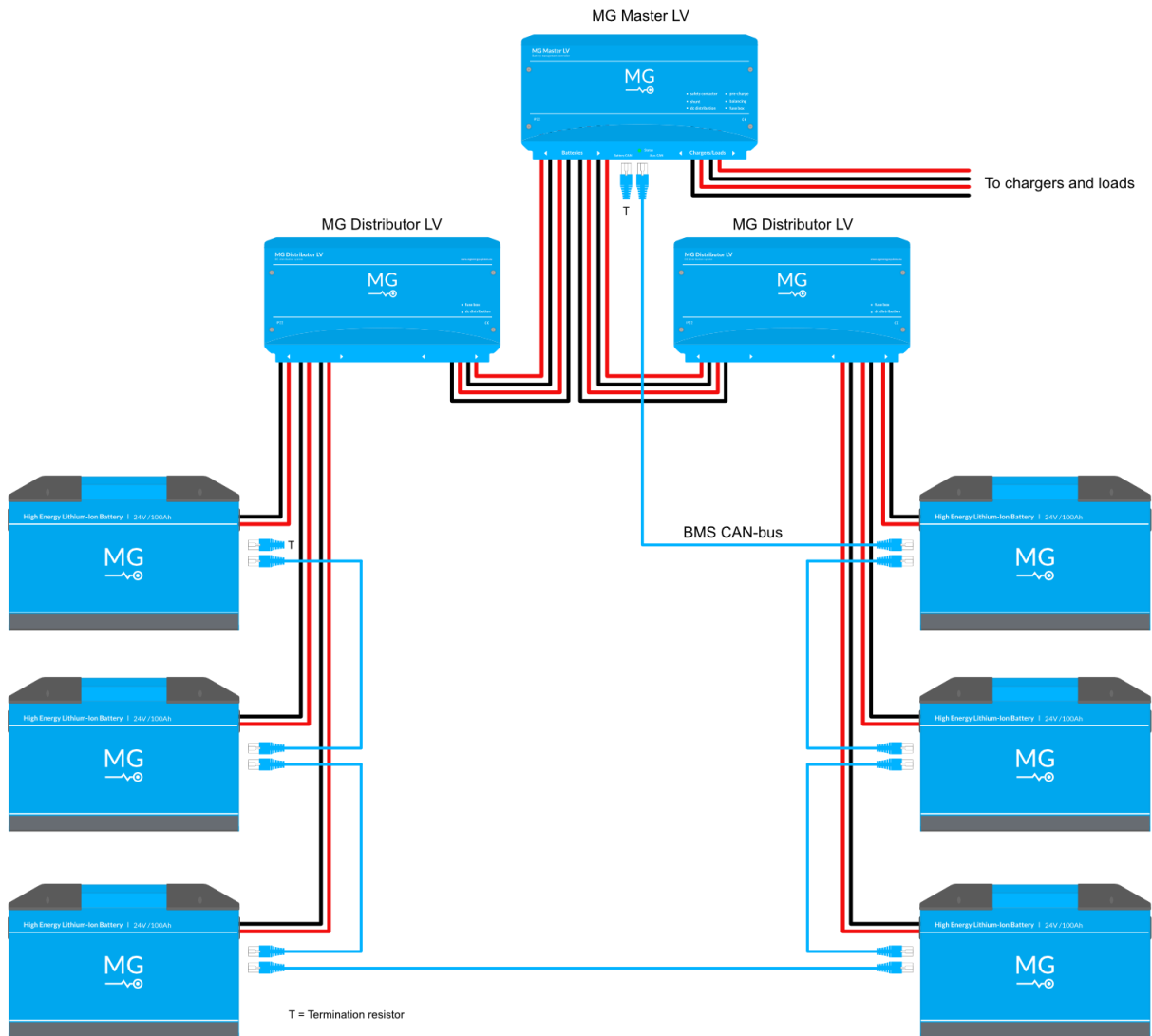

Figure 16 - Example of parallel connection with MG Distributor LV's

### 7.4.4 Paralleling using a custom bus bar connection system

Designing a custom DC-busbar system is beyond the scope of this manual.

#### 7.4.5 Series configuration

The battery modules can be connected in series up to 144 VDC which requires the use of the MG Master HV.

Table 12 shows the maximum number of battery modules in series per battery type.

Table 12 - Maximum number of modules in series per battery type.

Article number	Voltage range	Maximum number of modules in series
MGLFP240280	24 VDC up to 96 VDC	4
MGLFP241280	24 VDC up to up 144 VDC	6
MGLFP242280	24 VDC up to up 460 VDC	16
MGLFP240230	24 VDC up to 96 VDC	4
MGLFP241230	24 VDC up to up 144 VDC	6
MGLFP242230	24 VDC up to up 460 VDC	16
MGLFP240304	24 VDC up to 96 VDC	4
MGLFP242304	24 VDC up to up 460 VDC	16



**WARNING:**

The fuse in each battery pole must be replaced by a non-fused battery pole when connecting more than 2 batteries in series. See chapter 6.2.3.1 for details and article number.



**WARNING:**

- Make sure high voltage battery systems are not accessible by non-authorized people or personnel.
- Mark the space of the high voltage battery installation with warning signs of **ELECTRICAL SHOCK** and the applicable signs according to the local rules and regulation.



**NOTICE:**

Some regulations require a manual battery or safety disconnect.

Figure 17 shows an example system of 6 battery modules in series connected to a MG Master HV.

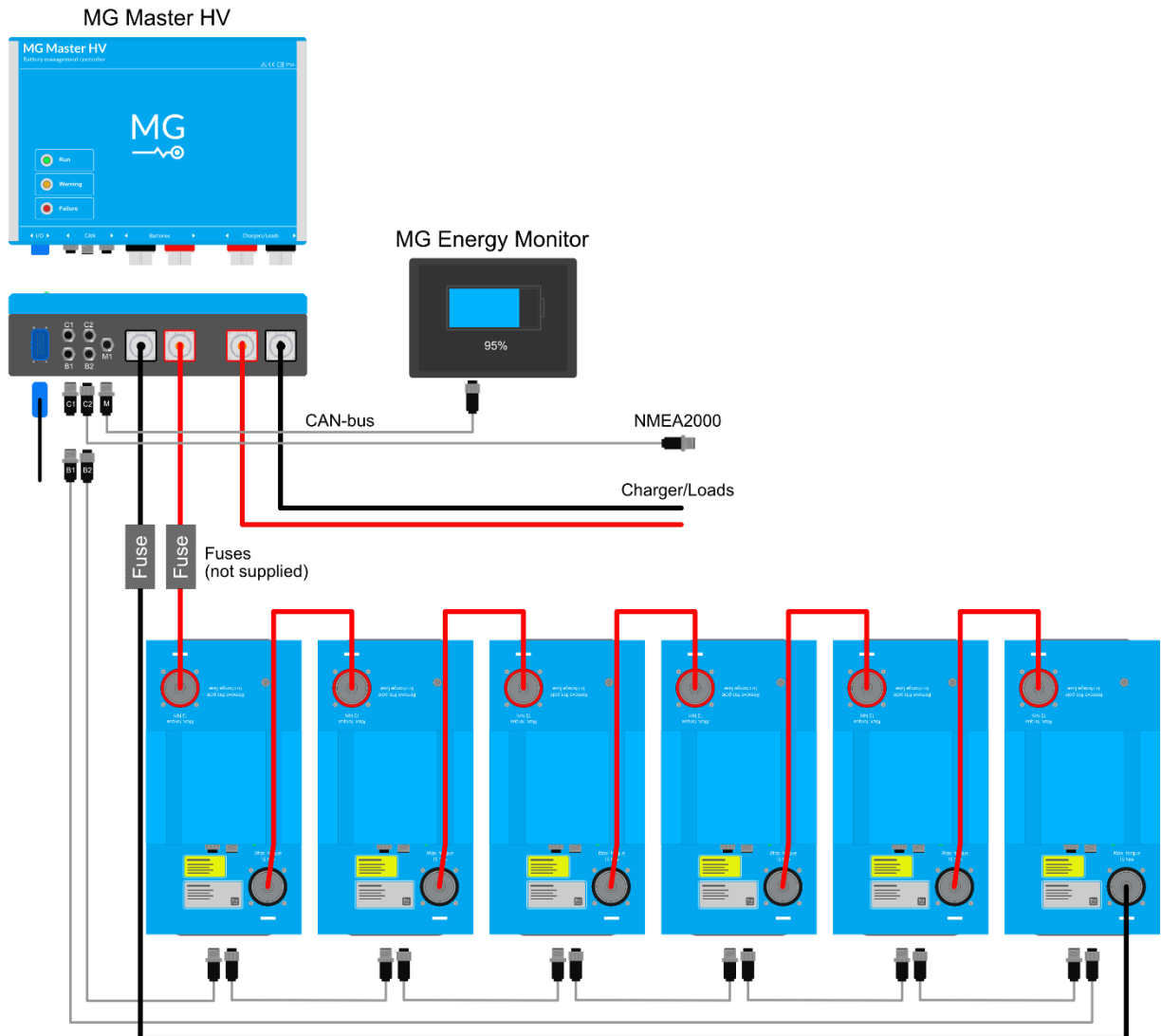

Figure 17 – Series configuration example



**WARNING:**

In systems with voltages > 58 V an insulation monitor is required.



**NOTICE:**

- Use the correct cable type for the applicable system voltage.
- Use the correct fuses for the applicable cable cross-section and voltage.

### 7.4.6 Charging

Any charger with constant voltage (CV) constant current (CC) charging can be connected to the MG battery system. Important is that the charger can be stopped by the MG Master BMS when the batteries are fully charged. Therefore the charger needs to have the ability to stop and start it remotely with a dry contact. There are also a number of chargers available that are digitally controlled by the MG Master BMS. Refer to the MG Master LV or MG Master HV manual for more details.

#### 7.4.6.1 Periodic charging

It is important to charge the batteries regularly to 100%. This is necessary to recalibrate the State-Of-Charge. The time of this period is depending on the application and usage.

#### 7.4.6.2 Charger settings

Chargers that are controlled with on/off need to use the following voltage settings.

<b>Absorption voltage</b>	28,2 VDC
<b>Float voltage</b>	26,4 VDC

This is the voltage setting for one battery. Multiply this by the number of batteries in series for system voltages > 24 VDC.

## 8 INSTALLATION

Read the installation instructions in this chapter before commencing installation activities.

Additional information for installation:

- Installation video: [LFP 24V](#)
- Quick installation guide: [LFP 24V](#)
- [Technical drawings](#)
- [Application Notes](#)



---

**WARNING:**

Before continuing make sure the following instructions are met:

- Ensure that the connection cables are provided with fuses and circuit breakers.
- Never replace a protective device by a component of a different type. Refer to the ordering information sections of this manual or contact manufacturer for a correct replacement.
- Before switching the device on, check whether the available DC bus voltage range conforms to the configuration of the product as described in the manual.
- Ensure that the equipment is used under the correct operating conditions. Never operate it in a wet or dusty environment.
- Ensure that there is always sufficient free space around the product.
- Install the product in an environment that can sustain some heat. Ensure therefore that there are no chemicals, plastic parts, curtains or other textiles, etc. in the immediate vicinity of the equipment.



---

**ELECTRICAL HAZARD:**

- Wear applicable personal protective equipment when working on a battery system.
  - Use insulated tools when working on a battery system.
  - Make sure the locale health and safety regulations for working on battery systems are followed.
- 

### 8.1 Tooling

The required tools during installation are the following:

- Phillips screwdriver PH1 (insulated);
- Torque wrench M5 (8 mm) + M8 (13 mm) (insulated);

## 8.2 Installation procedures

Below the basic installation procedures at battery module level.

1. Mount the battery module: mounting procedure;
2. Equipotential bonding of the battery modules: equipotential bonding procedure;
3. Connect the battery module electrically: electrical connection procedure;
4. Installing the top ingress protection cover;
5. Replacing the internal fuse: Fuse replacing procedure;



**NOTICE:**

During installation a check form needs to be used to log the installation procedure. This log will be checked during commissioning.

## 8.3 Mounting procedure

The battery module has no specific mounting points. Instead it can be mounted with brackets or straps as stated in chapter 7.3.3.

## 8.4 Electrical connection procedure

The battery module can be used in combination with other battery modules of the same type and always in combination with a MG Master BMS.

Before any electrical connection can be performed, the top covers from the battery module must be removed.



**ELECTRICAL HAZARD:**

The battery modules can be placed in series up to 144 VDC. Make sure to wear proper insulation gloves and safety goggles.



**ELECTRICAL HAZARD:**

Before connecting the DC cables, make sure the other ends are protected or connected.



**8.4.1 Equipotential bonding connection procedure**

The equipotential bonding connection is located on top of the battery module next to the positive power connection as shown in chapter 6.1. Equipotential bonding connection scheme and the required wire cross-section depend on local standards and regulation. The typical used wire cross-section is 6 mm<sup>2</sup>.

When the system voltage is > 58 Vdc then connect a 6 mm<sup>2</sup> wire from the equipotential bonding point of each battery module in the system to a Protective Earth (PE). Tighten it with 4Nm.

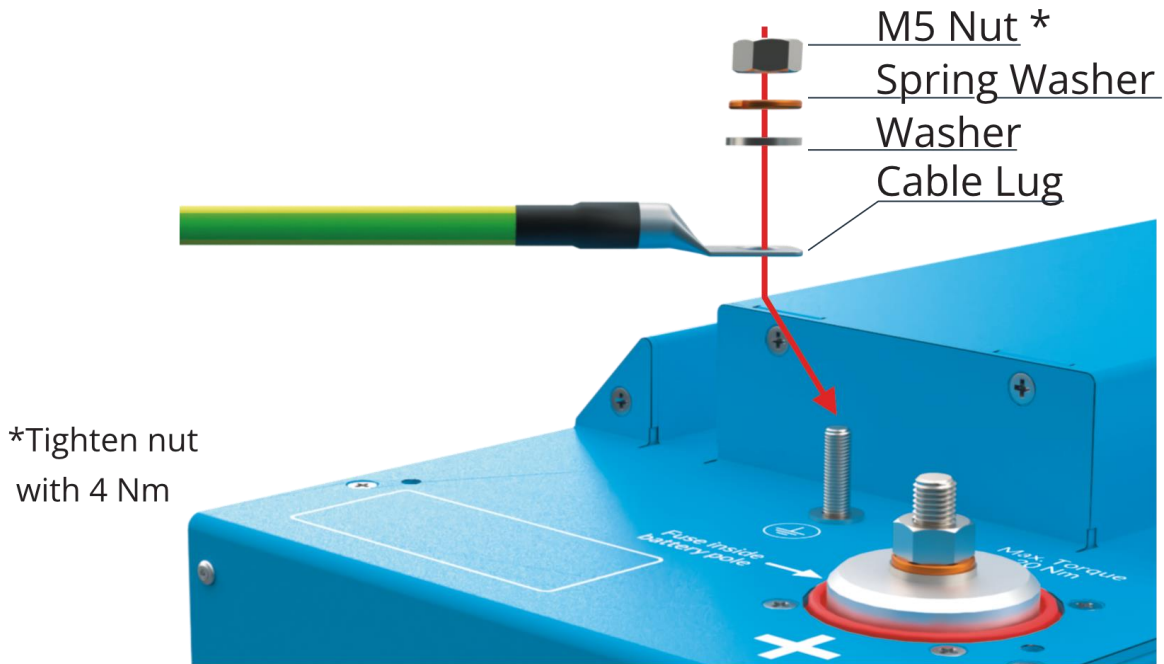

Figure 18 - Connection example of Equipotential bonding



**ELECTRICAL HAZARD:**

Make sure the equipotential bonding cable is routed with free clearance of the battery pole.

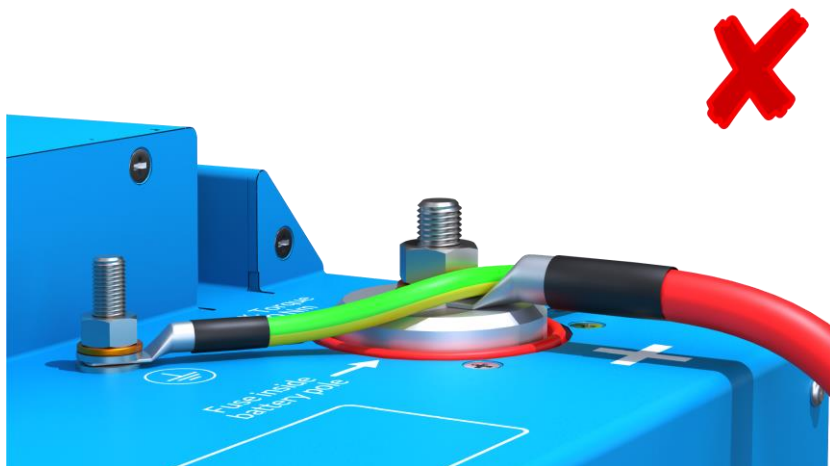

Figure 19 - Wrong routing of equipotential bonding wire

**8.4.2 Positive and negative power connection procedure**

Before connecting any power cable make sure the routing of the power cables is made properly. Figure 20 shows a wrong connection of the power cable which will interfere with the CAN-Bus connectors and protection cover. Figure 21 shows a good connection of the power cable. Refer to chapter 7.4 for details about the power connections.



Figure 20 - Wrong connection of power cable

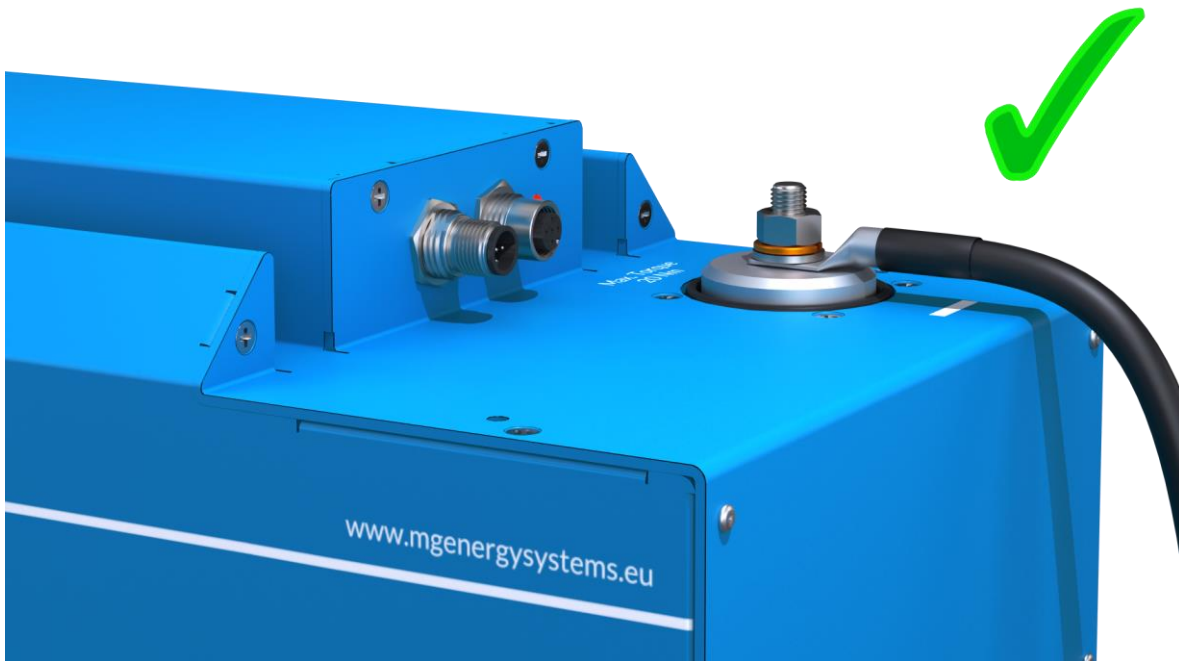
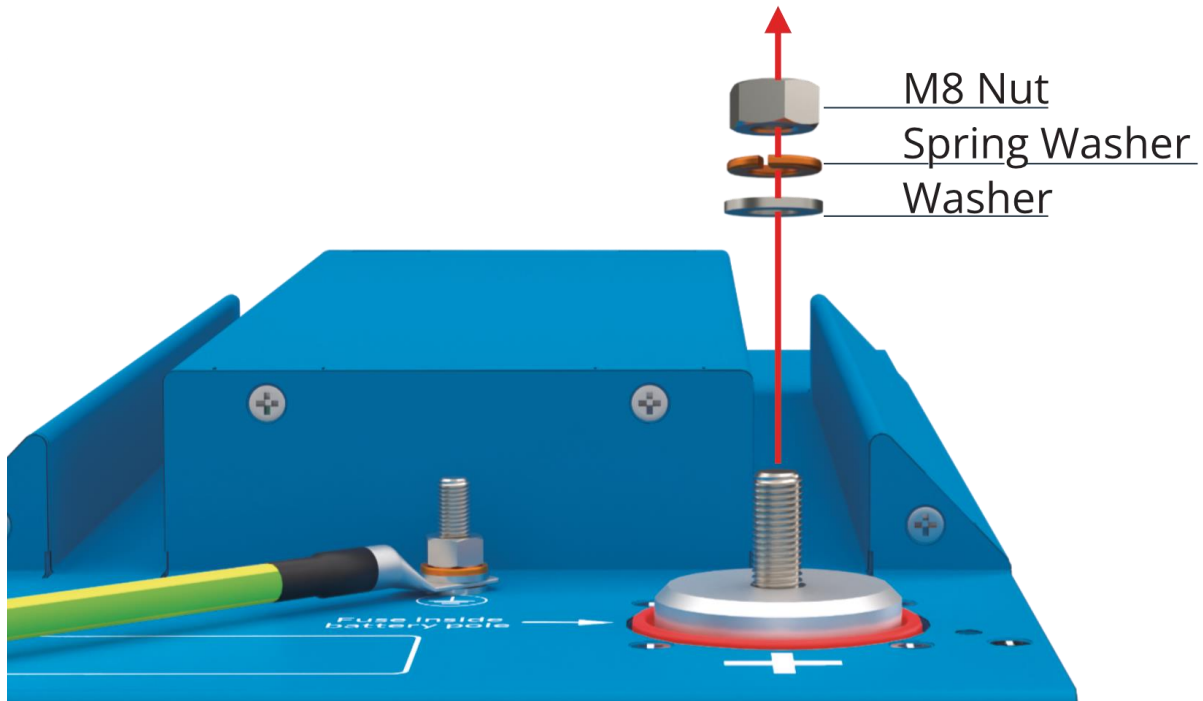

Figure 21 - Good connection of power cable

Below the procedure for connecting the power cables to the battery.

1. Remove the nut, spring washer and washer from the positive battery pole.



---

**NOTICE:**

When removing the nut and washers from the battery pole, it will become loose. This is normal. When the cable is connected and the nut and washers are back in place it will be tightened again.

---

2. Clean the battery pole and the cable lug's contact surfaces for a low resistance connection.

- Depending on the system voltage or specific system design the battery fuse must be removed. In case of **system voltage > 58 Vdc**: replace battery pole + fuse with non-fused battery pole.

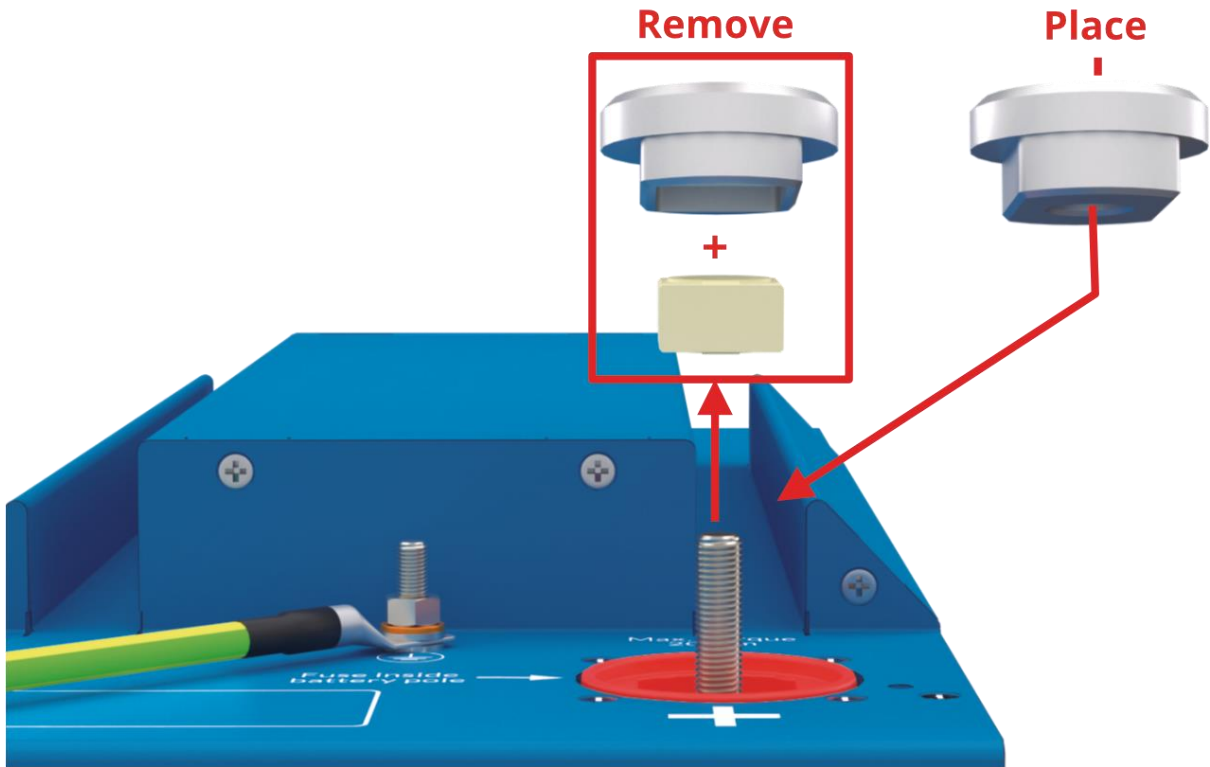

- Connect the positive power cable with M8 cable lug to the M8 bolt as shown and place back the washer, spring washer and nut. Tighten the nut with a torque of 20 Nm.

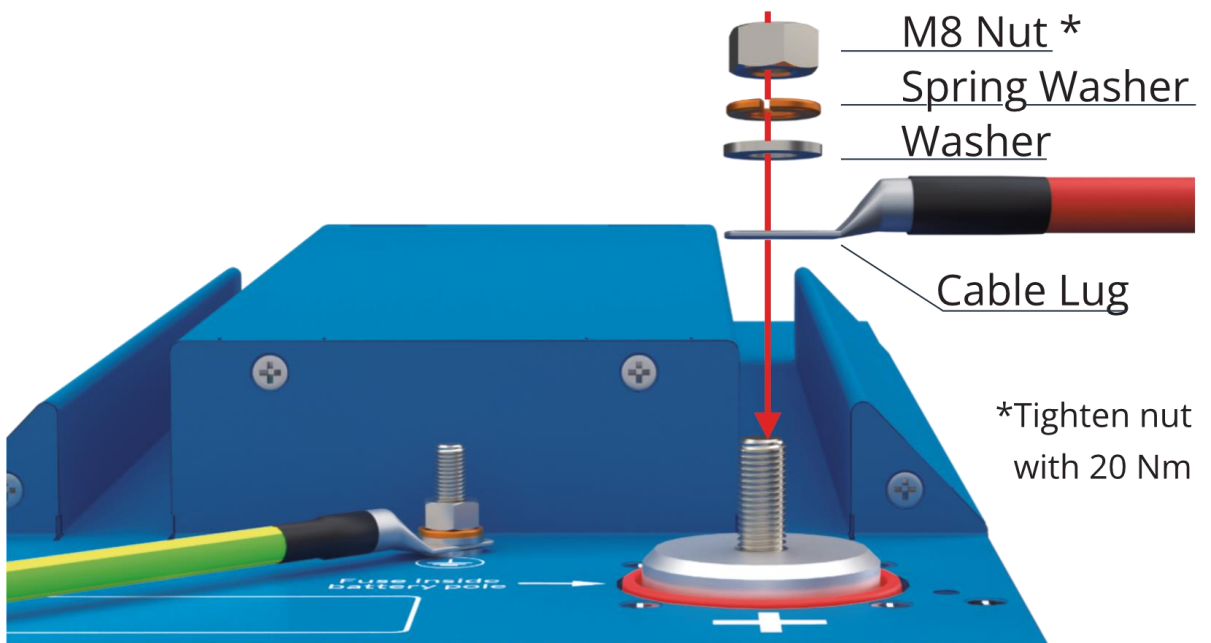

- Remove the nut, spring washer and washer from the negative battery pole.

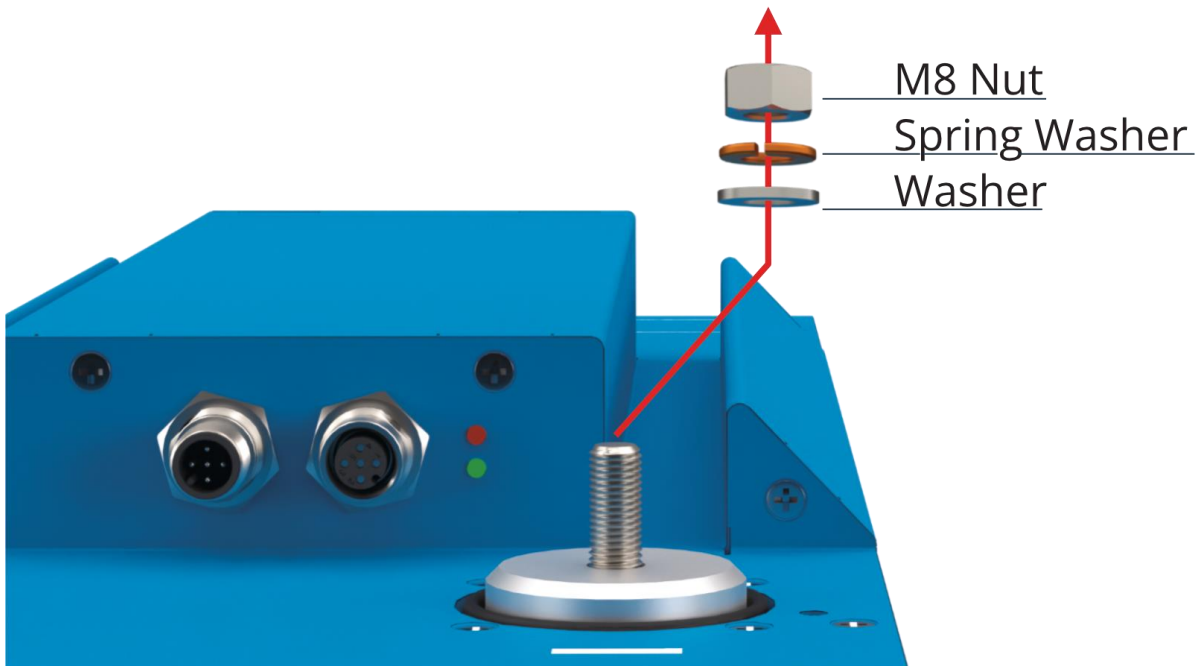

- Clean the battery pole and the cable lug's contact surfaces for a low resistance connection.
- Connect the negative power cable with M8 cable lug to the M8 bolt as shown and place back the washer, spring washer and nut. Tighten the nut with a torque of 20 Nm.

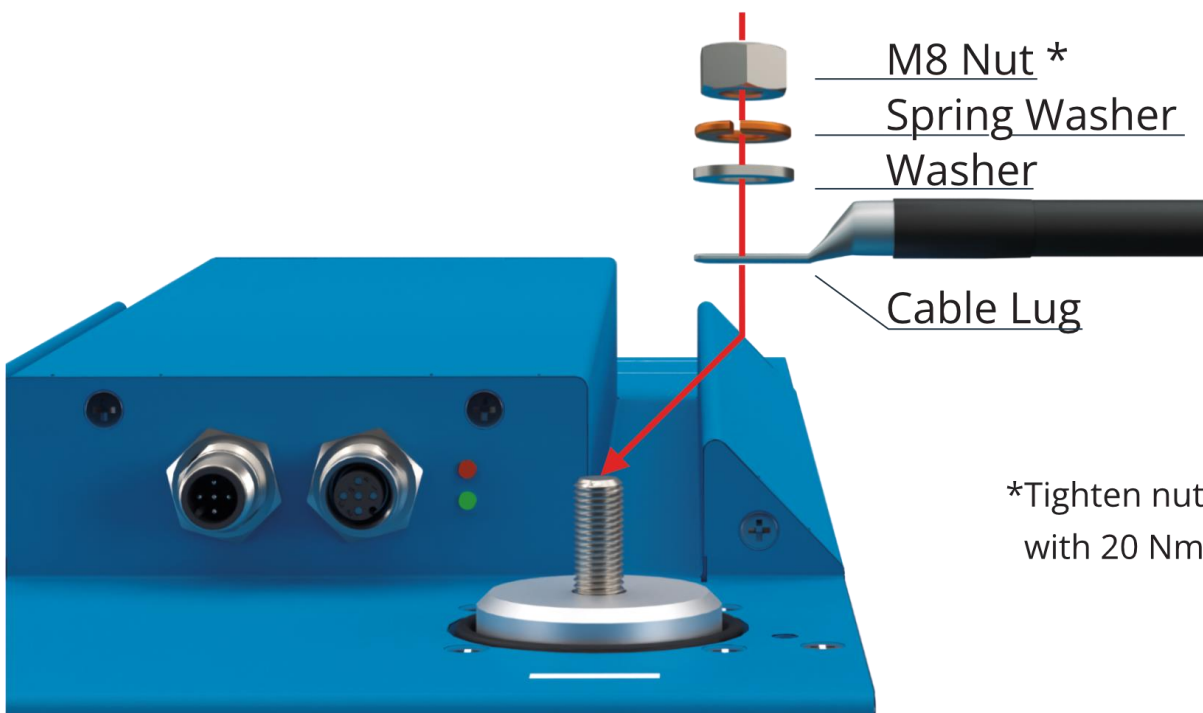

**WARNING:**

Make sure the cable lug is directly mounted to the battery pole without any washers or nuts in between.

---

**WARNING:**

Stacking of multiple cable lugs is possible however we strongly advise against it. Connection resistance increases which, in time, might lead to excessive heat generation.

---

**ELECTRICAL HAZARD:**

Make sure power cables are routed properly to avoid sharp edges and other possible causes of a short-circuit. It is recommended to protect the cables with a conduit system.

---

### 8.4.3 CAN-bus connection procedure

The battery modules communicated with a CAN-bus system to the MG Master BMS. This connection can either be with RJ45 or M12 connectors depending on the battery type. The same topology is used for both connector types. However, the MG Master LV and MG Master HV can have different connection configurations. For more information about the CAN-bus communication connection possibilities, refer to the MG Master LV, MG Master HV manual.

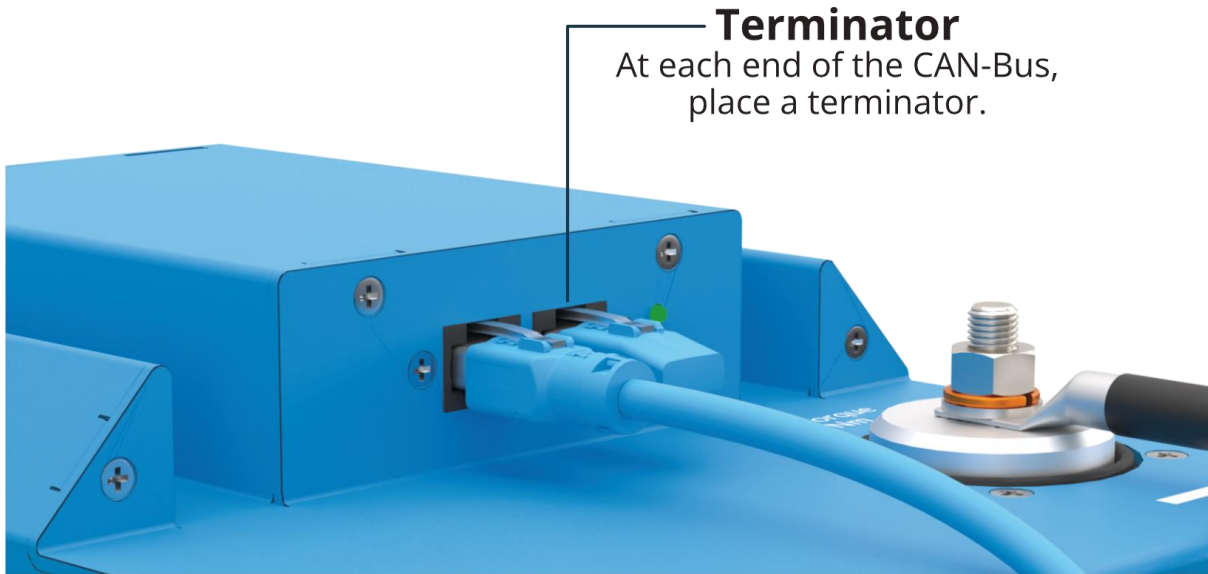

Figure 22 - RJ45 battery connection



Figure 23 - M12 battery connection

### 8.4.3.1 Basic connection

The most basic connection is as following:

1. Start with a CAN-bus cable at the MG Master BMS, the Battery CAN-Bus, and go to the first battery.
2. Connect from the first to the second battery. Repeat this until the last battery module.
3. Place a termination resistor at the end and begin of the CAN-bus network.

*RJ45 connection:*

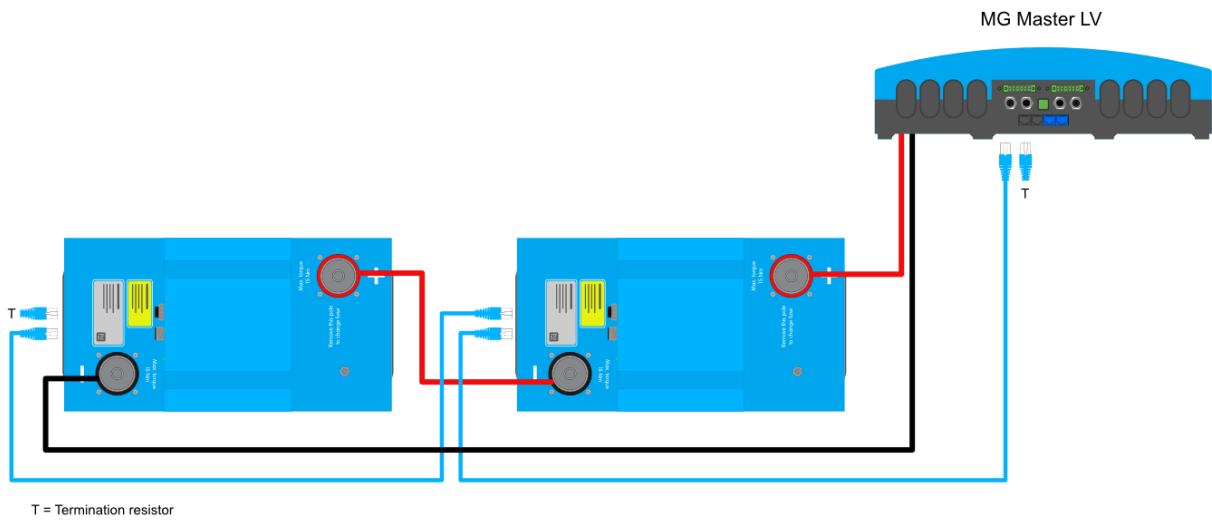

*M12 connection:*

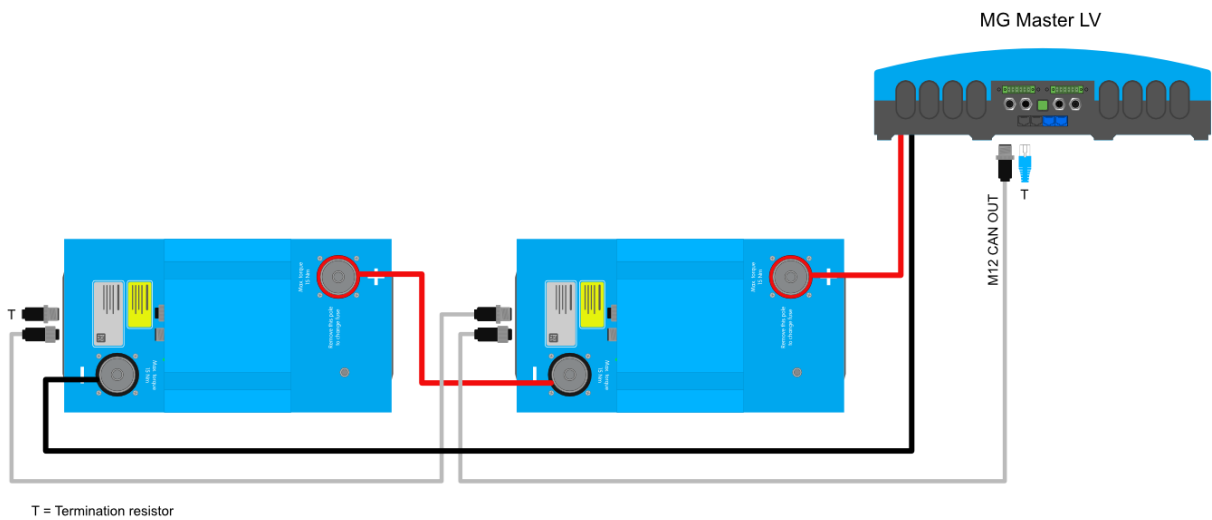



**8.4.3.2 Example including MG Energy Monitor**

In this example an MG Energy Monitor is connected to the battery system using M12 to RJ45 converter cables.

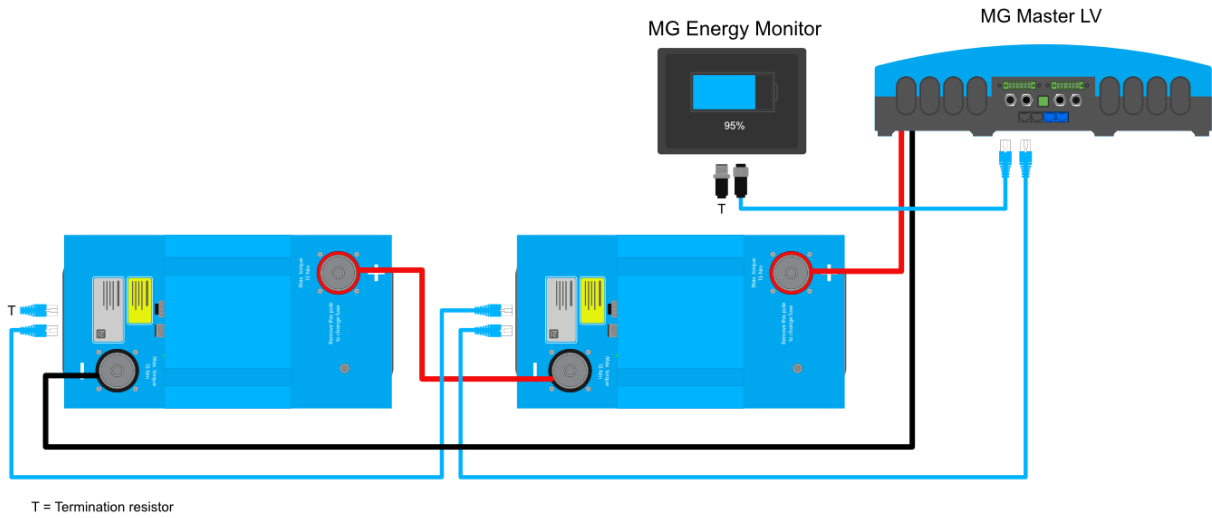

**WARNING:**

Use the termination resistors delivered with the MG Master BMS. 3<sup>rd</sup> party termination resistors could damage the devices, because pinning could be different.

### 8.5 Installing the top ingress protection cover

The top ingress protection cover is used to protect the battery module against the ingress of liquids from the top. This chapter describes the installation of the cover.



Figure 24 - Top ingress protection cover for LFP 230 and LFP 280

The two black covers needs to be mounted before the top ingress protection cover can be mounted.

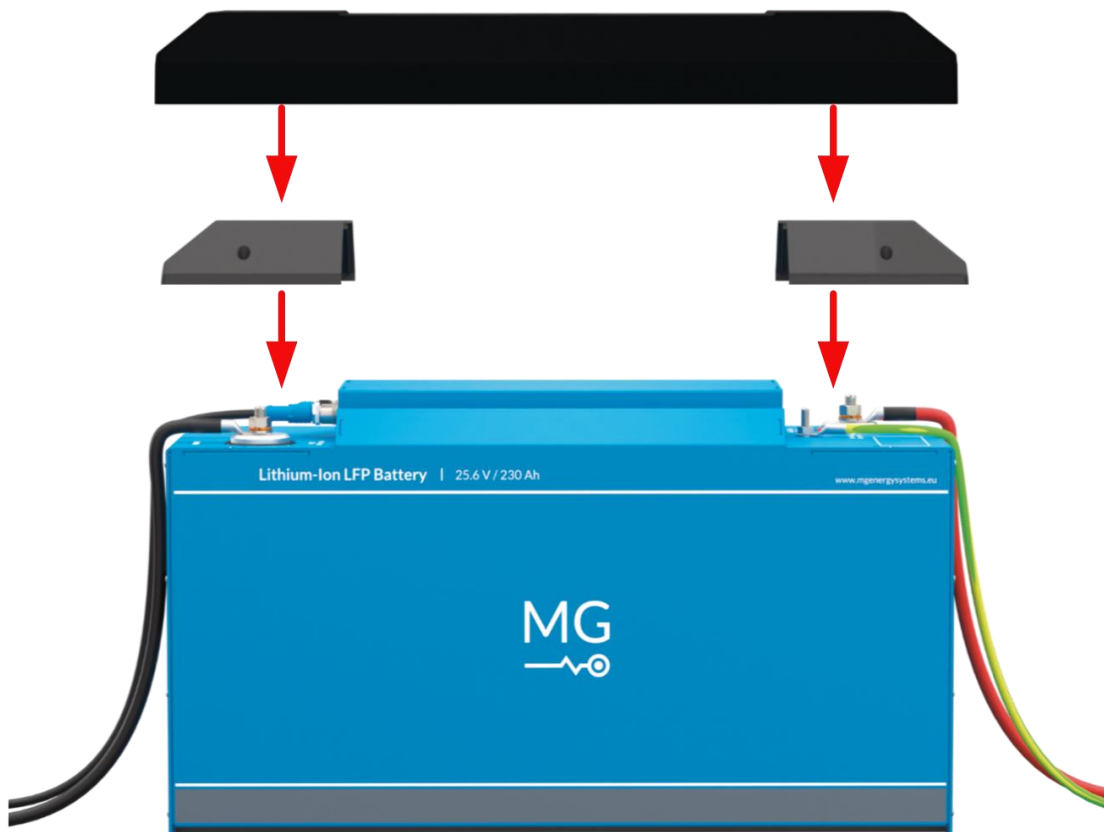

Figure 25 - Mounting ingress cover on top of battery module

### 8.5.1 Placing the cover

The cover can be placed over the modules even when the cables are connected. The flexibility of the cover makes it to fit to almost every existing installation. In some cases the cover must be cut to make it fit. See chapter 8.5.3 for details on cutting the cover.

1. Place the ingress protection cover at three corners first as shown in Figure 26.



Figure 26 - First place three corners

2. Press the last corner in place until it snaps.



Figure 27 - Press the last corner

Figure 28 shows an example of a cover installed on a battery module.

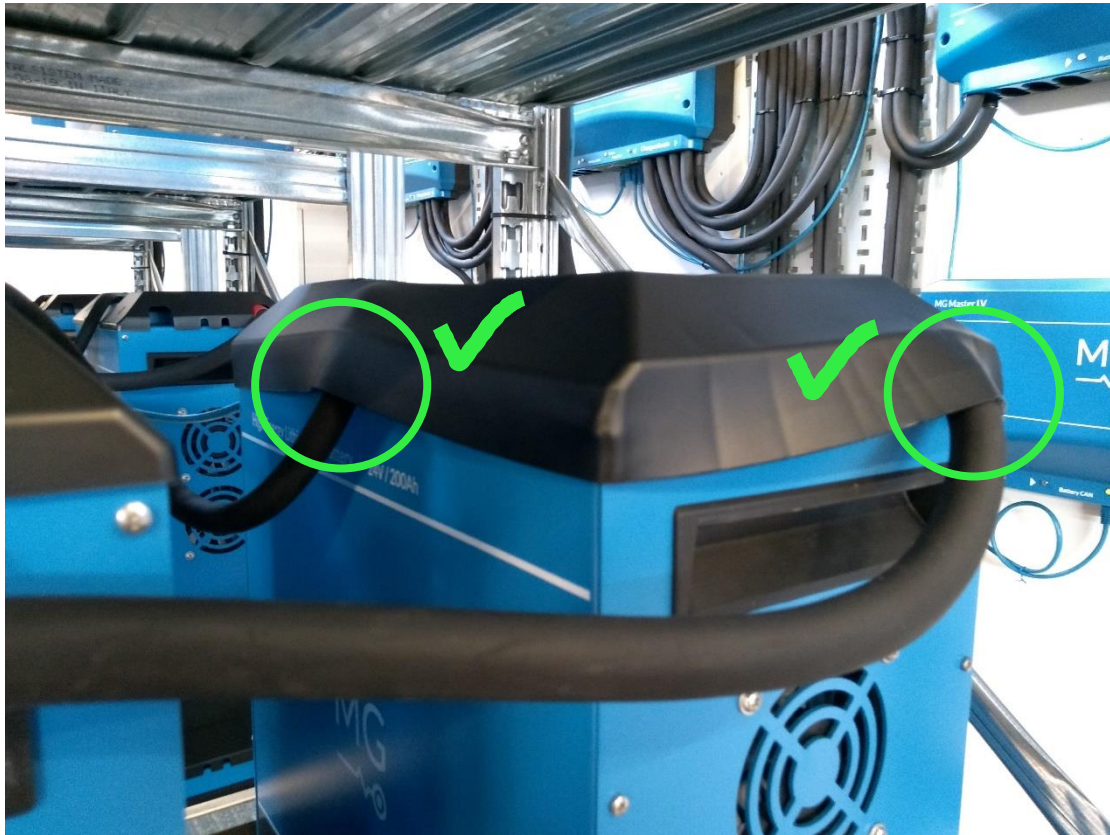
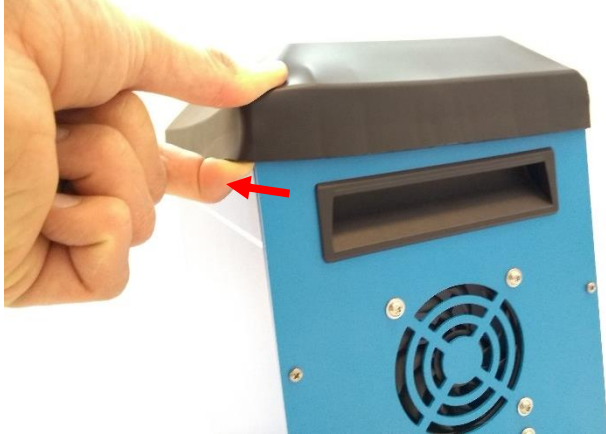

Figure 28 - Example of cover in installation

### 8.5.2 Removing the cover

1. Pull **one** corner away from the battery



2. Lift the cover to release it.

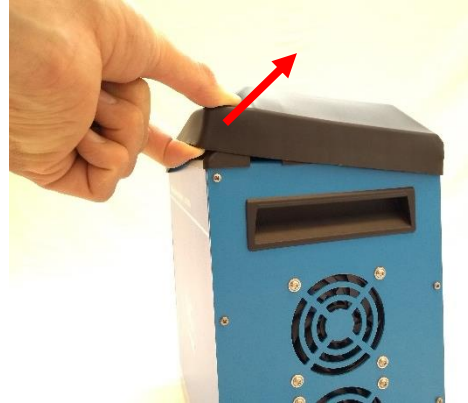

### 8.5.3 Cutting the cover

If cutting is required use the cut lines at the inside of the cover as guide.

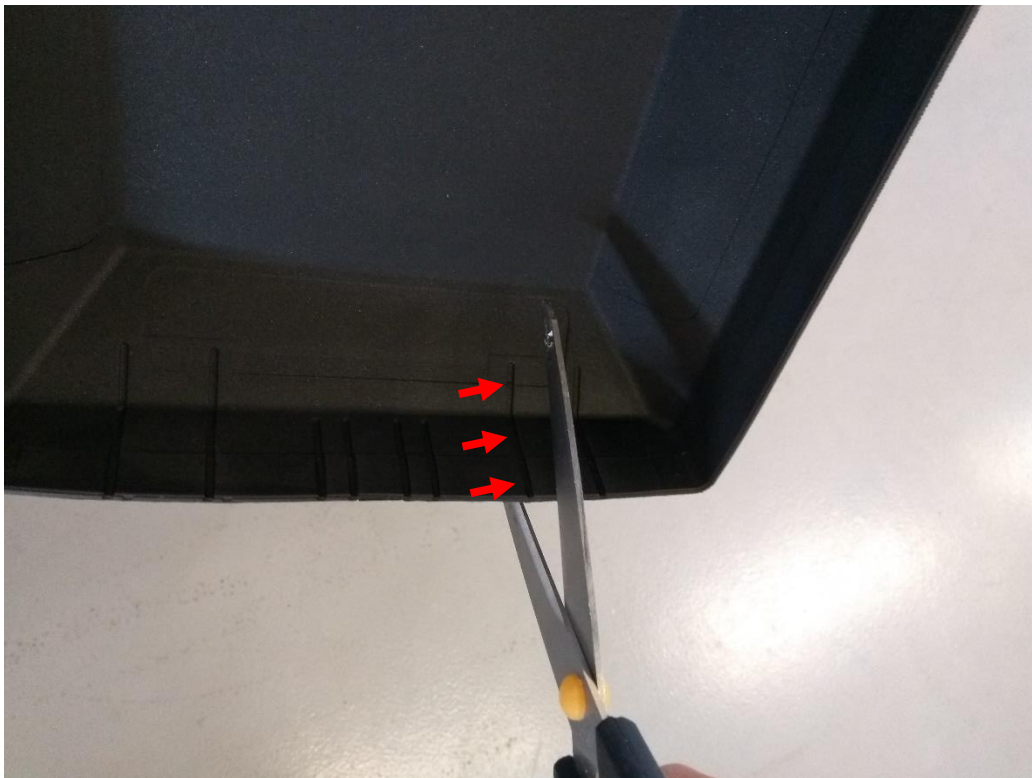

**Do not** remove the flap because it prevents water drips of entering the battery module or cable.



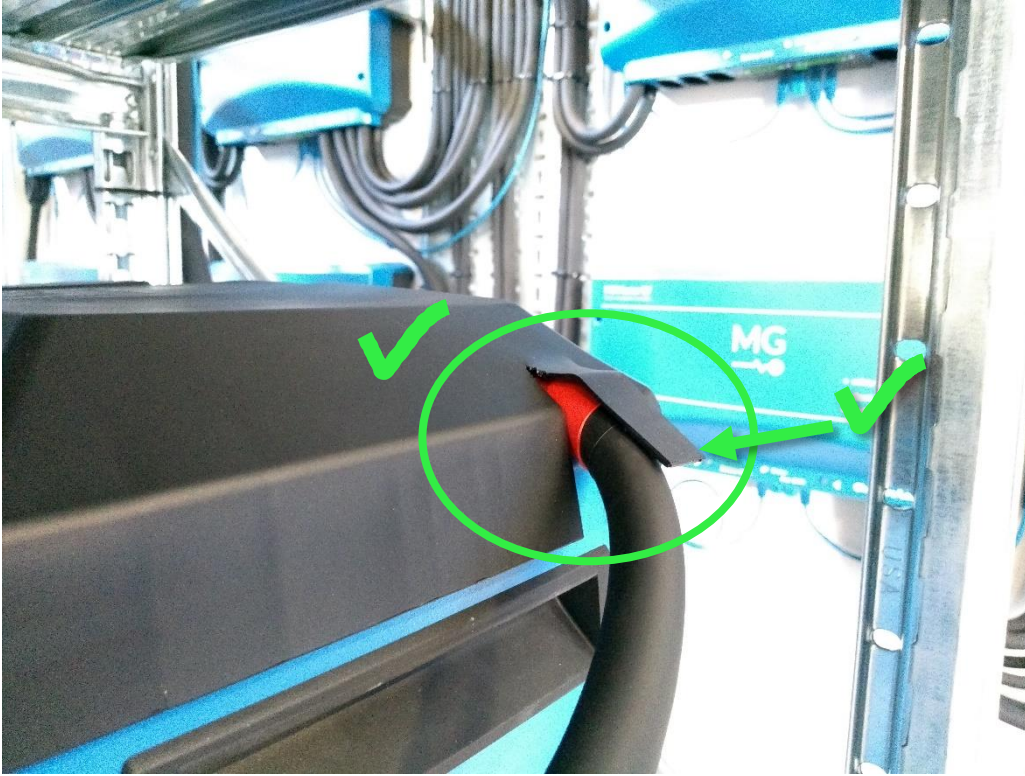

Figure 29 - Example to cutting out cable release.

## 8.6 Fuse replacing procedure

Replacement of the fuse requires the battery system to shut down. The fuse can be replaced with a new fuse or with a non-fused battery pole.



**WARNING:**

- When replacing the fuse with a non-fused battery pole, the fuse for the string of batteries needs to be installed separately in the system.
- Do not use the battery unfused.

### 8.6.1 Non-fused battery pole

The non-fused battery pole is actually a regular negative battery pole. Figure 30 shows the difference between the two.

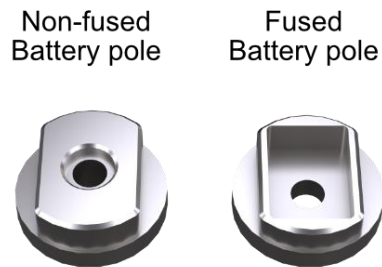
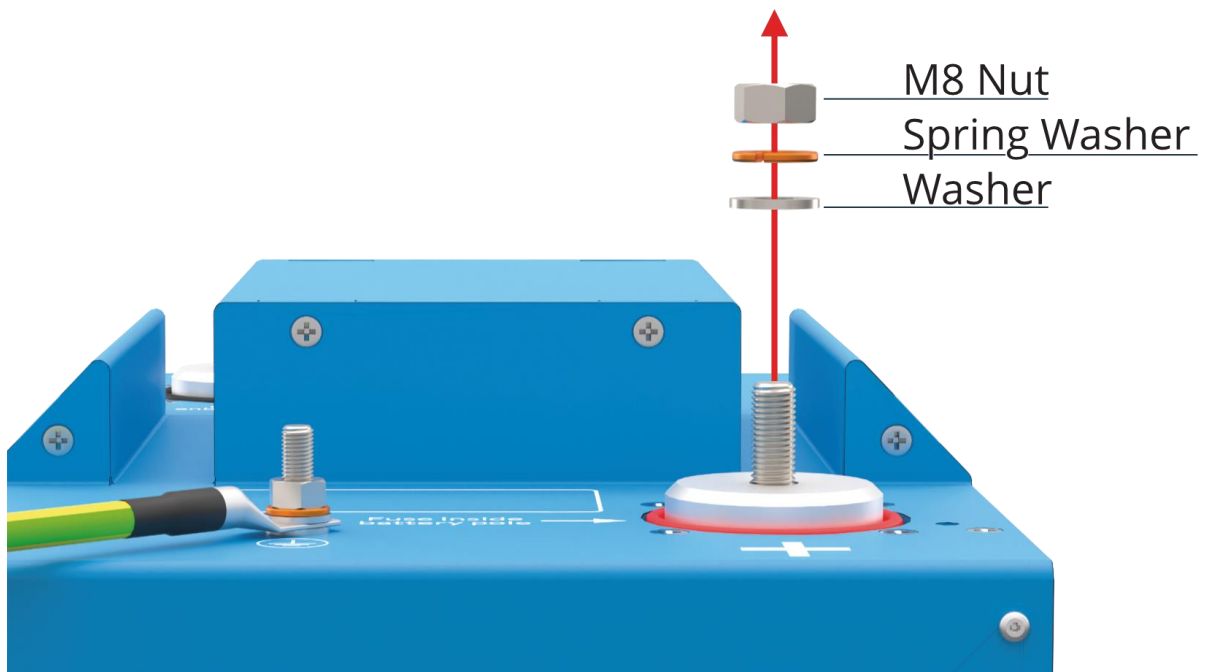

Figure 30 - Overview of negative and positive battery pole.

### 8.6.2 Replacement instructions

1. Remove the nut, spring washer and washer from the positive battery pole.



**NOTICE:**

When removing the nut and washers from the battery pole, it will become loose. This is normal. When the cable is connected and the nut and washers are back in place it will be tightened again.

2. Remove positive battery pole and fuse.

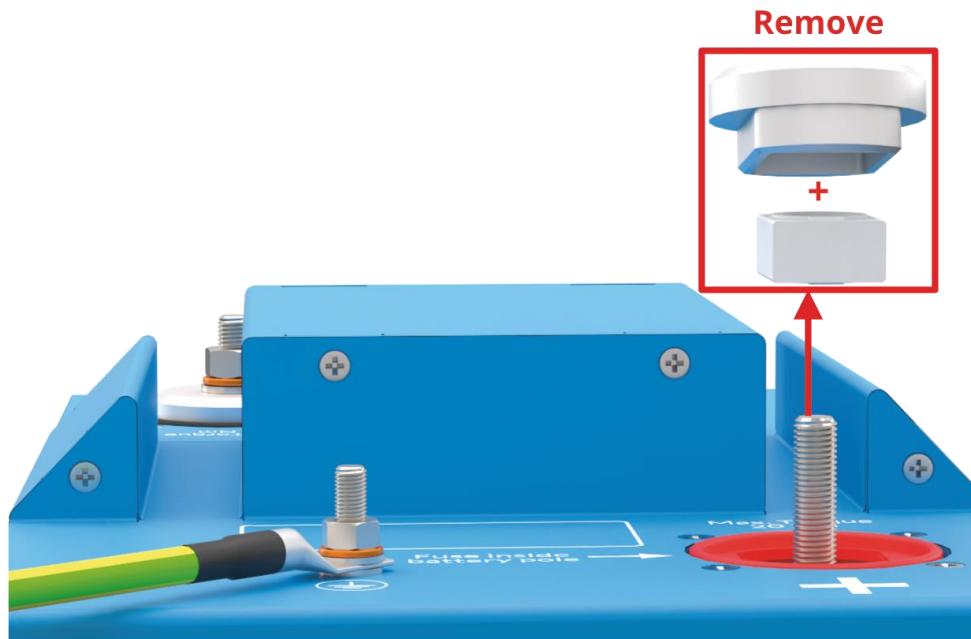

3. Now the fuse can be checked and replaced with a new one or it can be replaced with a non-fused battery pole. If the fuse is replaced with a non-fused battery pole then clean the battery pole with a fine sanding block (scotch-brite). Recommended is to add an electrical joint compound for better conduction.
4. Before connecting the power cable, the voltage of the battery module needs to be measured to check if it is the same as the parallel connected batteries. If not then charge/discharge the batteries separately to the same level.
5. Connect the power cables with the instructions of chapter 8.4.2.



## 9 COMMISSIONING

Table 13 shows a list of points that need to be checked after installation.

Table 13 - Commissioning steps procedure

	Description
<input type="checkbox"/>	Is a risk assessment performed?
<input type="checkbox"/>	Are the location and placement requirements in chapter 0 and 7.3 met?
<input type="checkbox"/>	Are the batteries installed in a location where there is no possibility fluids can enter the battery module from the top or bottom? For example installation under the seams of hatches.
<input type="checkbox"/>	Are the battery modules clean from any dust, metal pieces and loose wires?
<input type="checkbox"/>	Are the equipotential bonding cables connected, if applicable?
<input type="checkbox"/>	Are the battery fuses replaced in case of system voltage of > 58 Vdc?
<input type="checkbox"/>	Are all battery pole power connection tightened with 20 Nm?
<input type="checkbox"/>	Are all CAN-Bus cables connected?
<input type="checkbox"/>	Are CAN-bus termination resistors installed in the correct way?
<input type="checkbox"/>	Is there any equipment connected directly to the batteries? This is not allowed.
<input type="checkbox"/>	Is top ingress protection cover installed?
<input type="checkbox"/>	Perform a charge/discharge test run and measure the temperature of the battery terminals during the test. Is there excessive heat generation in the system or system components?
<input type="checkbox"/>	Make pictures of the installation.
<input type="checkbox"/>	Send the pictures and this form together with the system commissioning form to <a href="mailto:support@mgenerysystem.eu">support@mgenerysystem.eu</a> with the subject: <project name> - Commissioning.



### NOTICE:

For the system commissioning procedure, refer to the manual of the MG Master LV or MG Master HV. If no commissioning procedure is available in the manual, contact MG Energy Systems.

## 10 DECOMMISSIONING PROCEDURES

This chapter describes procedures to decommission the battery system or module in several situations.

### 10.1 Procedure: removing a malfunctioning battery module

This chapter describes the procedure to follow if a malfunction in a battery module has occurred.



---

**WARNING:**

- Use the correct personal safety gear.
  - The released gasses during a thermal runaway are explosive and toxic.
  - Always consult the local safety protocols before performing any procedures.
- 



---

**NOTICE:**

The procedures in this chapter are indicative and can differ depending on the situation, (local) regulations and standards. Therefore MG Energy Systems B.V. cannot accept responsibility for damage, injury, or expenses resulting thereof.

---

#### 10.1.1 Detecting malfunctioning

A malfunctioning battery module can lead to a number of different situations that takes the complete battery system out of operation. The list below shows the most plausible alarms that can occur on the MG Master BMS.

- High temperature alarm;
- Damaged temperature sensors alarm (at least 2);
- Damaged BMS: no communication, no temperatures, voltages etc;

Other signs of a malfunctioning battery module:

- Low insulation resistance;
- Leakage detection alarm;
- Smoke/gas released from the battery module enclosure;
- Enclosure of battery module has a higher temperature comparing to the other battery modules;
- A battery module emits an unusual smell.
- A battery module such a high temperature that it cannot be touched.
- A battery module changes colour and/or shape.

These alarms and signs, but not limited to, are an indication for a malfunctioning battery module.



---

**NOTICE:**

In case of the suspicion of a malfunctioning battery module or any anomalies pointing towards this. It is mandatory to stop the battery system from operating and contact MG Energy Systems B.V. for specific instructions.

---

### 10.1.2 Monitoring the battery module

Depending on the situation and damage, several actions may be taken.

#### 10.1.2.1 Example situation 1

One of the battery modules in a system is malfunctioning and it still communicating with the MG Master BMS. In that case the temperature of the particular battery module can be monitored by the MG Diagnostic Tool or any other monitoring system which is digitally connected to the MG Master BMS.

#### 10.1.2.2 Example situation 2

One of the battery modules in a system is malfunctioning and is not communicating anymore with the MG Master BMS. In that case it is advised to monitor the temperature of the battery module in another way, for example a thermal imaging camera or external temperature sensor(s).

### 10.1.3 Remove and secure the battery module

The following procedure is only applicable when the battery module has cooled down, and thermally stable to ensure a safe removal of the battery module.

1. Take the system out of operation. Contactors of the MG Master BMS open.
2. Disconnect the main power connectors or remove the fuses from the MG Master BMS and in other location of the battery system.
3. Find and inspect the particular battery module.
4. Before removing the battery module, verify whether the temperature has cooled down within safety levels. This can be checked with either a thermal imaging camera or using the MG Diagnostic Tool if possible.



**WARNING:**

Wear protective clothing and gloves to avoid injuries through heat.

---

5. Disconnect the power and communication cables from the particular battery module.



**ELECTRICAL HAZARD:**

When there is a low insulation resistance in the battery system or battery module, make sure using proper insulation gloves before touching any parts of the battery system.

---

6. Remove the battery module.
7. Place the battery module in a water filled container at a safe location, for example outside or in a special container. The temperature of the battery module will be kept low and the module is secured from a new event.



**NOTICE:**

In some cases it is not possible to remove and secure the battery module immediately. In those situations it is mandatory to constantly monitor the temperature of the battery module to be prepared for any emergency situation.

---

## 10.2 Procedure: removing a battery module from a functioning system

In some cases batteries need to be removed from a correct functioning system to be stored for a longer period of time and reinstalled later. This chapter describes the procedures for removing the batteries and prepare them for storage. Before starting the removal procedure make sure the battery bank is charged between 50% and 70% SoC.

### 10.2.1 Removing battery modules

The following procedure is only applicable when the battery module has cooled down, and thermally stable to ensure a safe removal of the battery modules.

1. Take the system out of operation. Contactors of the MG Master BMS open.
2. Disconnect the main power cables and/or fuses from the MG Master BMS.



---

**ELECTRICAL HAZARD:**

Use proper insulation gloves before removing any parts of the battery system.

---

3. Disconnect all power cables from the batteries.
4. Disconnect all communication cables from all batteries.
5. Remove each battery module one by one.
6. Prepare the modules for a long storage period.

### 10.2.2 Prepare the battery module for a longer storage period

Additional preparations are required when the battery modules are stored for a longer period of time and are removed from a correct operating system.

- Make sure the battery modules are charged between 50% and 70% SoC.
- Make sure the storage requirements from chapter 3.2 are met.

## 11 SERVICE

### 11.1 Maintenance

For maintenance it will be sufficient to inspect the following points once a year:

- Check the electrical connections on torque.
- Check if all communication connections are mated.
- Check for traces of water, oil, moisture, any other fluids or dust.
- Check for signs of corrosion.
- Clean the device.
- Check status with the [MG Diagnostic Tool](#), [MG Connect App](#) or [MG Energy Portal](#).



---

**ELECTRICAL HAZARD:**

Do not pour or spray water directly onto the device. When cleaning the device be aware that the connected battery string is a permanent energy source. Even when the device is turned off, the battery power connections might carry dangerous voltage levels.

---

#### 11.1.1 Cleaning

Cleaning of the device is best done using a dry or slightly damp cloth. Limit the use of cleaning agents. If a cleaning agent is to be used, use an electrically non-conductive cleaning agent is advised.

It is important to keep the battery spaces clean and tidy in order to minimise the need for cleaning. Prevent the use of moisture, vaporizing agents, oil, grease, etc. in the vicinity of the device.

### 11.2 End-of-life

The battery module is considered end-of-life if the SOH is decreased to 70 %. After this period it is strongly advised to replace the battery module to ensure safety.

### 11.3 Disposal

Batteries marked with the recycling symbol must be processed locally via a recognized recycling agency. By agreement, they may be returned to the manufacturer. Batteries must not be mixed with domestic or industrial waste. Before disposal it is recommended to discharge the battery module to 0 VDC.

## 12 BOUNDARY LIMITS

The boundary limits that are used by the master for the battery modules are listed in this chapter. A level will be triggered when a boundary condition is true for a defined period of time.

Battery thresholds are compatible with the following master BMS firmware versions or higher:

- Master HV 1.20 or higher
- Master LV 1.30 or higher

### 12.1 Limits

Boundary limits are defined to keep the battery within manufacturer's specifications.

The tables with the boundary limits consist of:

- Name, description of the situation;
- Action, action on respond of the boundary, set/clear or failsafe;
- Boundary condition, contains a value that is needed for an action in combination with the time;
- Time that the boundary condition has to be present before it will be triggered. Times indicated with "+" start counting if the previous boundary condition above is set.

#### 12.1.1 Cell voltage

Table 14 Cell voltage boundary limits slave BMS

Name	Action	Boundary condition	Time
Almost charged	Set	$\geq 3440$ mV	10 sec.
	Clear	$< 3390$ mV	10 sec.
Charged	Set	$\geq 3520$ mV	+10 sec.
	Clear	$< 3440$ mV	10 sec.
Over voltage warning	Set	$\geq 3600$ mV	+20 sec.
	Clear	$< 3520$ mV	20 sec.
Over voltage critical	Failsafe	$\geq 3650$ mV	+5 sec.
Almost discharged	Set	$\leq 3100$ mV	10 sec.
	Clear	$> 3150$ mV	10 sec.
Discharged	Set	$\leq 3000$ mV	+10 sec.
	Clear	$> 3100$ mV	10 sec.
Under voltage warning	Set	$\leq 2900$ mV	+20 sec.
	Clear	$> 3000$ mV	20 sec.
Under voltage critical	Failsafe	$\leq 2850$ mV	+5 sec.

### 12.1.2 Cell temperature charging

Table 15 Cell temperature charging boundary limits slave BMS

Name	Action	Boundary condition	Time
Over temperature alert	Set	$\geq 43\text{ }^{\circ}\text{C}$	5 sec.
	Clear	$< 42\text{ }^{\circ}\text{C}$	5 sec.
Over temperature	Set	$\geq 45\text{ }^{\circ}\text{C}$	+20 sec.
	Clear	$< 43\text{ }^{\circ}\text{C}$	20 sec.
Over temperature critical	Failsafe	$\geq 50\text{ }^{\circ}\text{C}$ and charge current $> 5\%$ battery capacity	+60 sec.
Under temperature alert	Set	$\leq 1\text{ }^{\circ}\text{C}$	5 sec.
	Clear	$> 2\text{ }^{\circ}\text{C}$	5 sec.
Under temperature	Set	$\leq 0\text{ }^{\circ}\text{C}$	+20 sec.
	Clear	$> 1\text{ }^{\circ}\text{C}$	20 sec.
Under temperature critical	Failsafe	$\leq -5\text{ }^{\circ}\text{C}$ and charge current $> 5\%$ battery capacity	+60 sec.

### 12.1.3 Cell temperature discharging

Table 16 Cell temperature discharging boundary limits slave BMS

Name	Action	Boundary condition	Time
Over temperature alert	Set	$\geq 53\text{ }^{\circ}\text{C}$	5 sec.
	Clear	$< 52\text{ }^{\circ}\text{C}$	5 sec.
Over temperature	Set	$\geq 55\text{ }^{\circ}\text{C}$	+20 sec.
	Clear	$< 53\text{ }^{\circ}\text{C}$	20 sec.
Over temperature critical	Failsafe	$\geq 60\text{ }^{\circ}\text{C}$	+60 sec.
Under temperature alert	Set	$\leq -19\text{ }^{\circ}\text{C}$	5 sec.
	Clear	$> -18\text{ }^{\circ}\text{C}$	5 sec.
Under temperature	Set	$\leq -20\text{ }^{\circ}\text{C}$	+20 sec.
	Clear	$> -19\text{ }^{\circ}\text{C}$	20 sec.
Under temperature critical	Failsafe	$\leq -25\text{ }^{\circ}\text{C}$ and discharge current $> 10\%$ battery capacity	+60 sec.

### 12.1.4 Power terminal temperature

Table 17 Power terminal temperature boundary limits slave BMS

Name	Action	Boundary condition	Time
Over temperature alert	Set	$\geq 60\text{ }^{\circ}\text{C}$	5 sec.
	Clear	$< 59\text{ }^{\circ}\text{C}$	5 sec.
Over temperature	Set	$\geq 70\text{ }^{\circ}\text{C}$	+20 sec.
	Clear	$< 60\text{ }^{\circ}\text{C}$	20 sec.
Over temperature critical	Failsafe	$\geq 80\text{ }^{\circ}\text{C}$	+60 sec.

### 12.1.5 Current

Table 18 Current boundary limits slave BMS

Name	Action	Boundary condition	Time
Charging over current warning	Set	> 1.0C	10 sec.
	Clear	<= 1.0C	10 sec.
Charging over current critical	Failsafe	> 2.4C	+20 sec.
Discharging over current warning	Set	> 1C	10 sec.
	Clear	<= 1C	10 sec.

### 12.1.6 Balancing

Table 19 Balancing boundary limits slave BMS

Name		Boundary condition	Time
Offset cell voltage		> 50 mV	5 min.
Balancing cell voltage		>= 3350 mV	5 min.
Battery pack current		current within ±5% battery capacity	5 min.



### **13 TECHNICAL SPECIFICATIONS**

The technical specifications of this product can be downloaded from the MG Download Center.

<https://downloads.mgennergysystems.eu/lfp24v/documents/technical-specification-en>

### **14 DIMENSIONS**

The dimensions of this product can be downloaded from the MG Download Center.

<https://downloads.mgennergysystems.eu/lfp24v/drawings>

## 15 CONTACT DETAILS

For specific questions please feel free to contact us.

### 15.1 Sales

For sales related questions, please contact a [local dealer](#).

For specific sales questions, please contact our sales team:

#### MG Sales team

[sales@menergysystems.eu](mailto:sales@menergysystems.eu)

### 15.2 Technical support

For technical support, please follow the steps below:

1. Consult the Manual.  
Manual can be found on the [MG Download Center](#).
2. Consult the [MG Support Center](#).
3. Watch the Installation Videos.  
Videos can be found on [MG's You Tube channel](#).
4. Check Your Software Version.  
Check and update the products software version to latest using the MG Connect App ([Apple](#) or [Android](#)) or [MG Diagnostic Tool](#).
5. Contact [MG Service Point](#).
6. Contact MG technical support.  
Send an email with your technical questions to [support@menergysystems.eu](mailto:support@menergysystems.eu).